

KBSW180101 SLAMWARE

SLAMWARE

- - SLAMWARE SDP
 - ZEUS
-
- -
 - SLAMWARE Breakout
 - Slamware Breakout
 - SLAMWARE Core
-
-
-
-
-
- Slamware SDK
 - Windows
 - Linux
 - iOS
 - Android
-

SLAMWARE SLAMTEC RPLIDAR 360° SLAMWARE Core

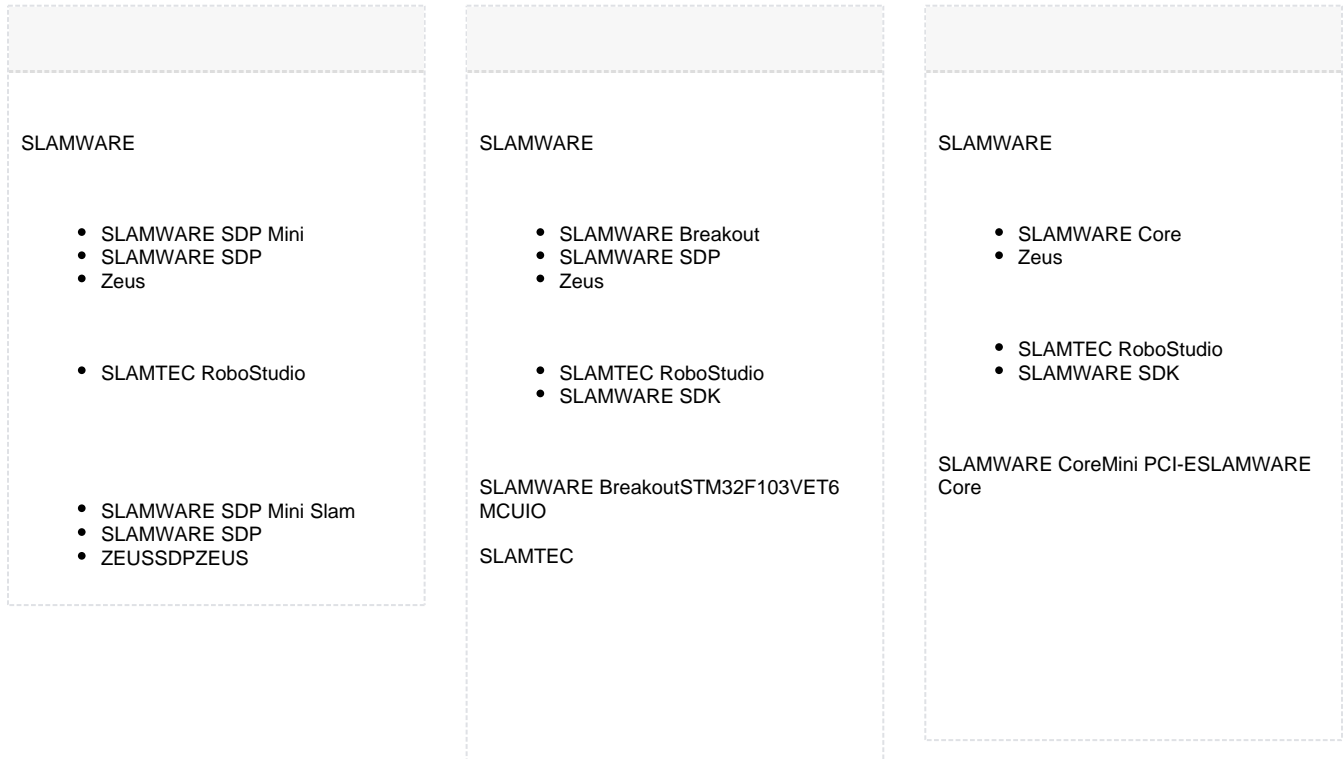

SLAMWARE SDP

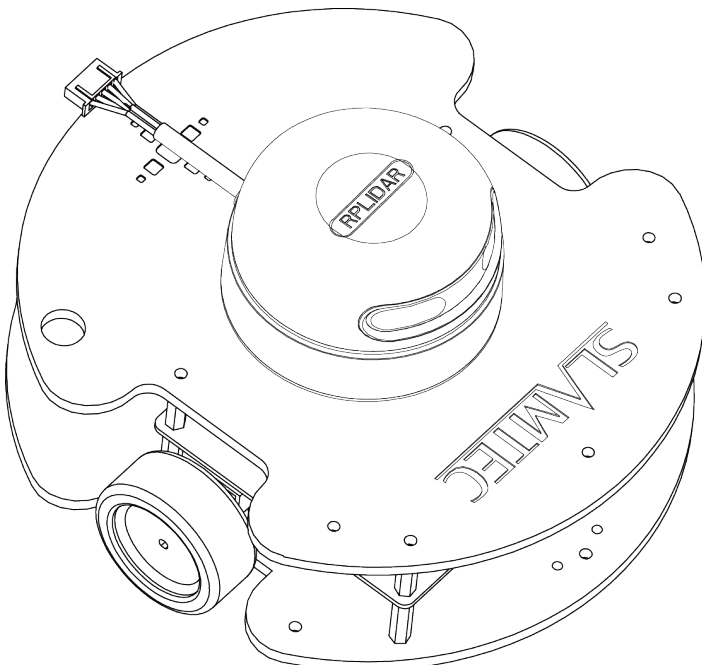
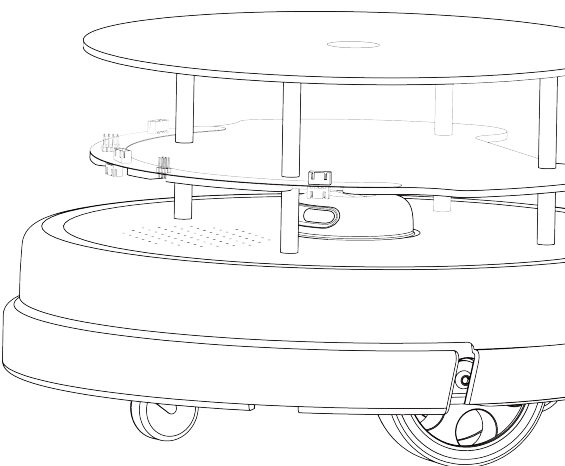
	SLAMWARE SDP Mini	SLAMWARE SDP
		
*	185mm * 100mm	400mm * 230 mm
	0.85kg	5.1kg
	<ul style="list-style-type: none"> • RPLIDAR 360° • 	<ul style="list-style-type: none"> • RPLIDAR 360° • • • • • • •
	<ul style="list-style-type: none"> • • • 	<ul style="list-style-type: none"> • • •
	<ul style="list-style-type: none"> • 	<ul style="list-style-type: none"> • • •
	<ul style="list-style-type: none"> • • • BreakoutBreakout 	<ul style="list-style-type: none"> • • • UI

ZEUS

ZEUSSLAMTECSLAMWARE

-
-
-

-
-
-

Zeus

Slamware Slamware Core Slamware SDK Slamware Core Slamware SDK Slamware SDK Windows Linux Android iOS Slamware

SLAMWARE 3RPLIDAR Slamware Core MCU SLAMWARE Core Control Bus MCU LIDAR Bus SLAMWARE

Slamware Core MCU Slamware Core

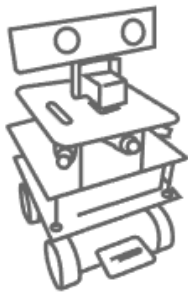

Your Robot

Control Bus

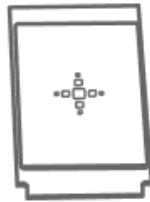

Slamware Core

LIDAR Bus

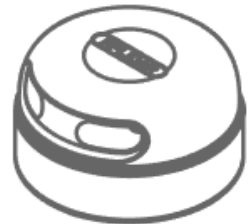

RPLIDAR

- Slamware Breakout
- Slamware Core

Slamware Breakout Breakout

SLAMWARE Breakout

SLAMWARE Breakout Slamware Core MCU--STM32F103VET6 IOSLAMWARE Breakout

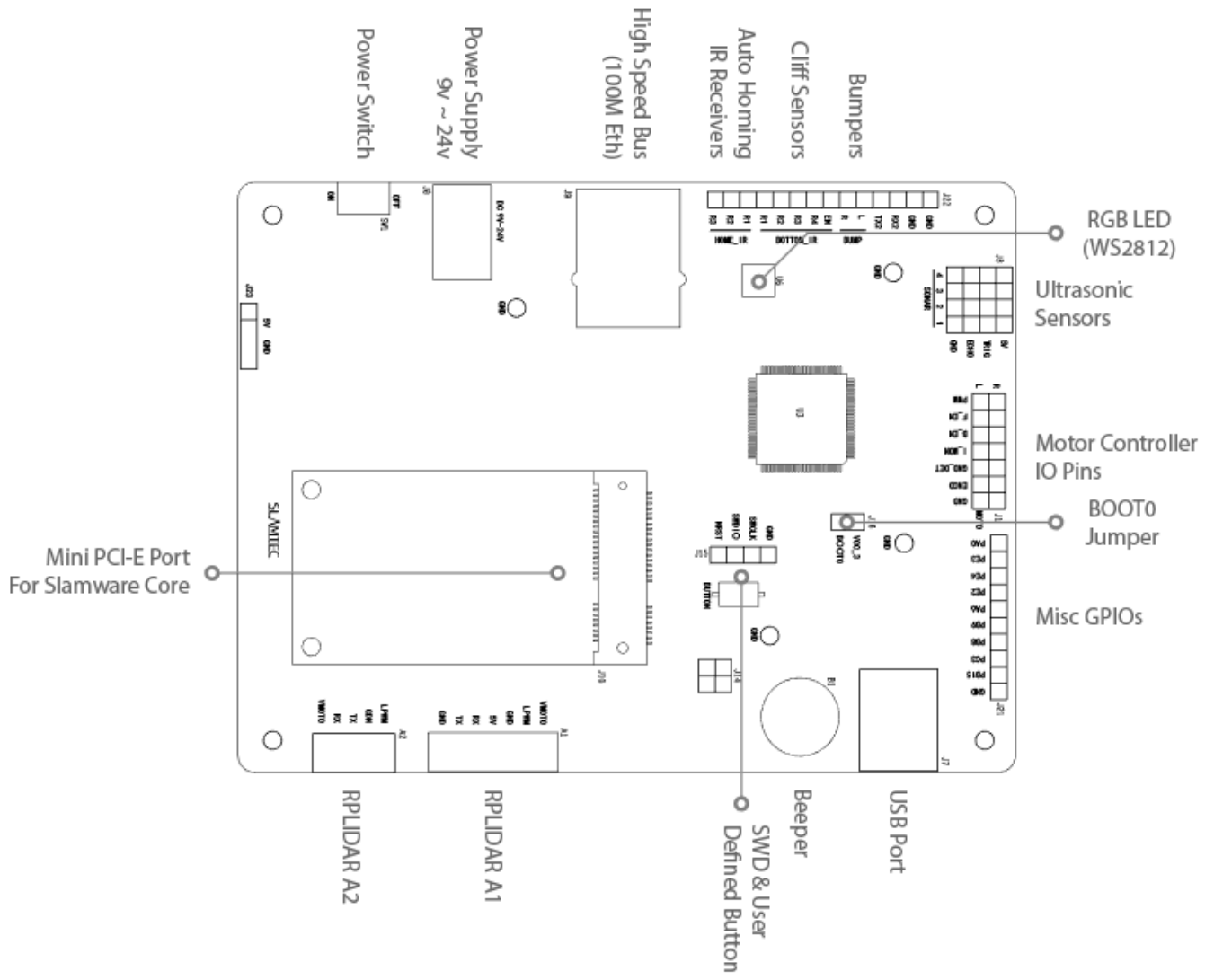

Slamware Breakout

Slamware BreakoutBreakout

-
-
-
-
-

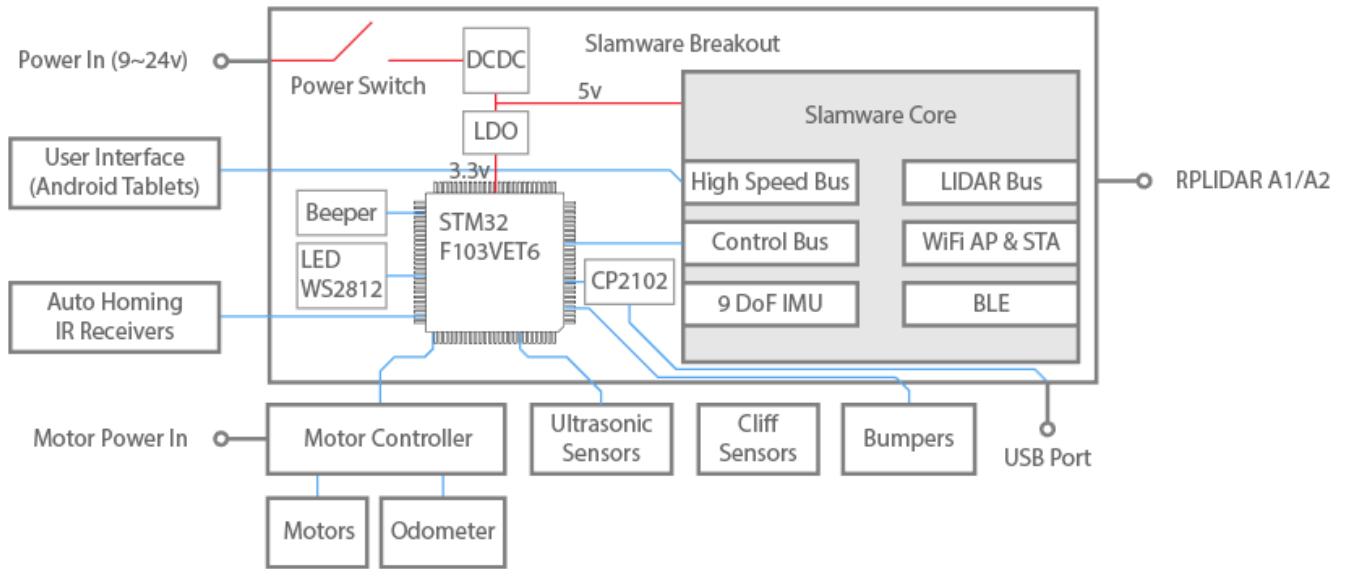

SLAMWARE Core

Slamware CoreMCUBreakout STM32F103VET6MCUSlamware CoreControl BusSlamware Core

MCUSlamwre CoreSlamware Core

-
- RPLIDAR
- MCUSLAMWARE Core
-
-
-
-

Slamware CoreBreakout

SLAMTECIARSTM32F103VET6

-
-
-
-
-
-
- Polling CommandSLAMWARE Core
- Event NotificationSLAMWARE Core
-

IAR7.6

Control Bus ProtocolSLAMWARE

iOSObjective-CSDK

-
-
-
-

Android

AndroidJavaSDK

-
-
-
-

Slamware Core