

LPX-T1

Indoor and Outdoor Laser Range Scanner
For Middle and Long Range Application

Introduction and Datasheet

Model: LPX-T1M4



CONTENTS	1
INTRODUCTION	3
SYSTEM CONNECTION	4
MECHANISM	4
SAFETY AND SCOPE	6
DATA OUTPUT	6
HIGH SPEED SAMPLING PROTOCOL AND COMPATIBILITY	7
APPLICATION SCENARIOS	7
SPECIFICATION	8
MEASUREMENT PERFORMANCE	8
MECHANICAL & ELECTRONIC SPECIFICATION	8
PERFORMANCE	8
ENVIRONMENT PARAMETERS	9
COORDINATE SYSTEM DEFINITION OF SCANNING DATA	9
NETWORK INTERFACE	10
POWER SUPPLY INTERFACE	10
SDK AND SUPPORT	12
MECHANICAL DIMENSIONS	13
REVISION HISTORY	14
APPENDIX	15
IMAGE AND TABLE INDEX	15



The LPX-T1 is the first generation of middle and long laser range scanner developed by SLAMTEC. It can take up to 60000 samples of laser ranging per second with high rotation speed.

LPX-T1 is a 2D laser ranger scanner. The system can perform a 2D 270-degree scan within a middle and long range. The generated 2D point cloud map data can be used in robot simultaneous localization and mapping, which is widely applied in actual applications like AGV(Automatic Guided Vehicle), service robot, lightweight automatic drive(park driverless car) and etc.

The typical scanning frequency of the LPX-T1 is between 20Hz and 40Hz. Under the typical frequency, the angular resolution is 0.12° . And the actual scanning frequency can be freely adjusted within the 20-40Hz range according to the requirements of users.

The LPX-T1 adopts the high performance laser TOF ranging system developed by SLAMTEC, which lets the LPX-T1 have excellent performance in all kinds of indoor environment and outdoor environment. Meanwhile, before leaving the factory, every LPX-T1 has passed the strict testing to ensure the laser output power meet the standards of FDA Class I.

System connection

The LPX-T1 consists of a range scanner core and the mechanical powering part which makes the core rotate at a high speed. When it functions normally, the scanner will rotate and scan clockwise. And users can get the range scan data via the communication interface of the RPLIDAR and control the starting, stopping and rotating speed of the rotate motor via PWM.

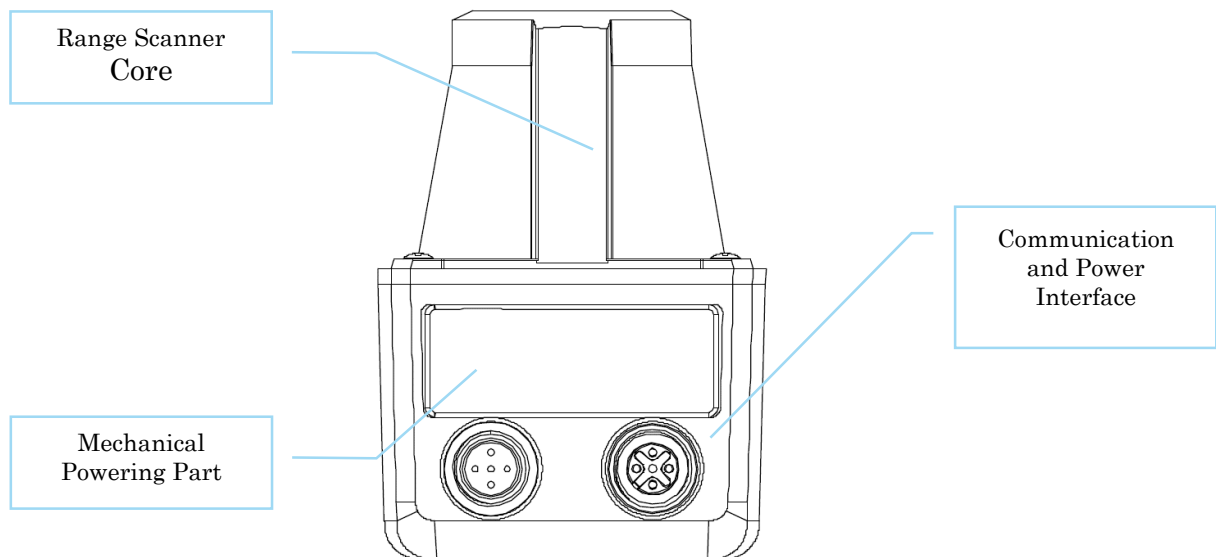

Figure 1-1 RPLIDAR System Composition

The LPX-T1 comes with a rotation speed detection and adaptive system. The system will adjust the angular resolution automatically according to the actual rotating speed. If the actual speed of the RPLIDAR is required, the host system can get the related data via communication interface.

The detailed specification about power and communication interface can be found in the following sections.

Mechanism

The LPX-T1 is based on laser TOF ranging technology and adopts the high-speed vision acquisition and processing hardware developed by SLAMTEC. The system ranges more than 60000 times per second.

During every ranging process, the LPX-T1 emits narrow pulse infrared laser signal and the laser signal is then reflected by the detected object. The returned signal is then sampled by vision acquisition system in RPLIDAR and the processor

embedded in RPLIDAR starts processing the sample data and outputs distance value and angle value between object and RPLIDAR via communication interface.

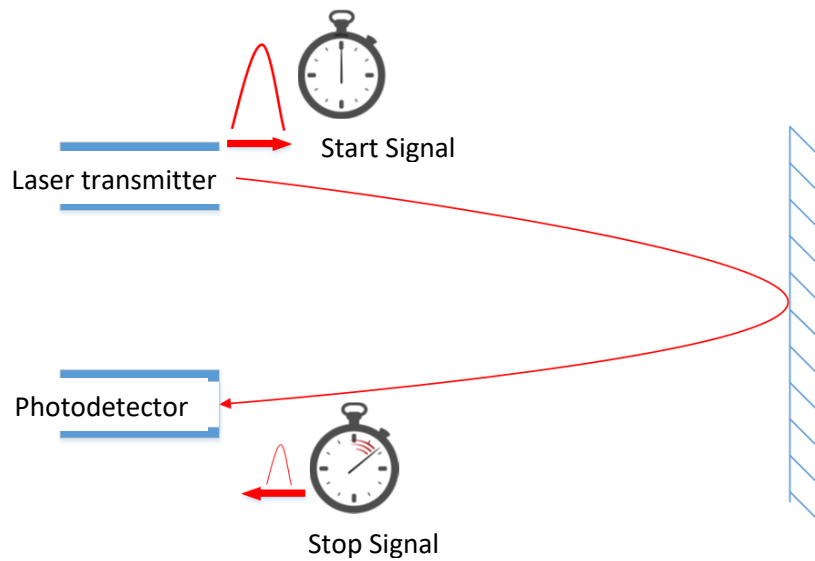
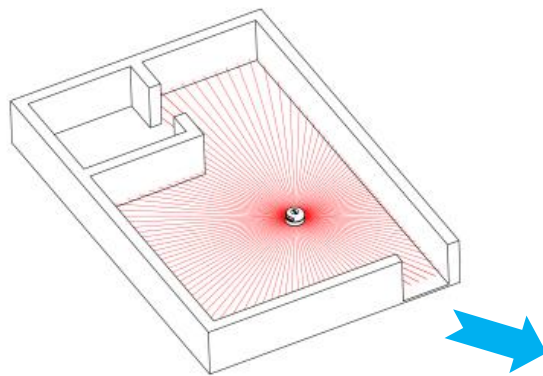

Figure 1-2 The Working Mechanism of LPX-T1

When drove by the motor system, the range scanner core will rotate clockwise and perform the 270-degree scan for the current environment.



*Note : The LIDAR scan image is not directly relative to the environment showed here. Illustrative purpose only.

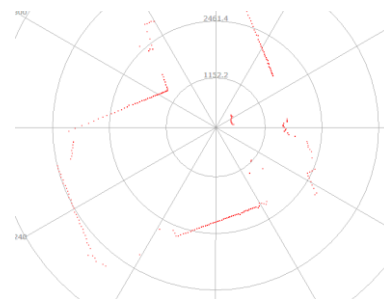

Figure 1-3 The Obtained Environment Map from RPLIDAR Scanning

Safety and Scope



Class I

The LPX-T1 system uses a low power infrared laser as its light source. The laser emits light in a very short time frame which can ensure its safety to human and pet, and it reaches Class I laser safety standard.

The ambient light and sunlight interfere with the working performance of all the laser ranging devices. The anti-interference mode designed by SLAMTEC can effectively avoid the interference from ambient light and sunlight during ranging scanning process, which makes LPX-T1 work excellent in all kinds of indoor environment and outdoor environment.

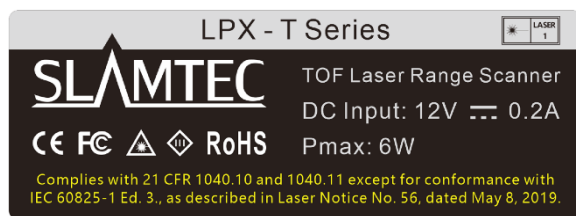

Warning label



label paste location

Data Output

During the working process, the LPX-T1 will output the sampling data via the communication interface.

The data of each sampling point contains the following information:

For detailed data format and protocol of communication interfaces, please contact SLAMTEC.

Data type	Unit	Description
Distance	mm	The actual distance between LPX T1 range scanner core and the sampling point
Angle	degree	The angle between the sampling point and the LPX ranging direction.
Quality		The quality information of the current sampling point, which is proportionate to the reflectivity of the tested object.
Flag	-	The start for a new rotation of LPX-T1

Figure 1-4 LPX Sampling Data Information

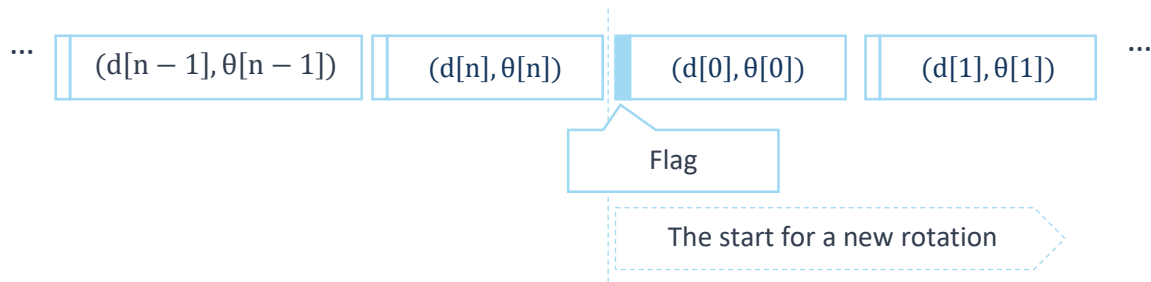

Figure 1-5 LPX Sampling Point Data Frame

The continuous output of LPX-T1 contains the above sampling data frame. Host systems can configure the format for the output data and stop LPX-T1 outputting data by sending a control command. For detailed operation, please contact SLAMTEC for details.

High Speed Sampling Protocol and Compatibility

The LPX-T1 adopts the newly extended high speed sampling protocol for outputting the 60000 times per second laser range scan data. Users are required to update the matched SDK or modify the original driver and use the new protocol to use the 60000 times per second mode of LPX-T1. Please check the related protocol documents for details.

Application Scenarios

The LPX-T1 can be used in the following application scenarios:

Robot simultaneous localization and mapping (SLAM)

AGV (Automatic Guided Vehicle)

Service Robot

Lightweight automatic drive (park driverless car)

Safeguard and security

Surveying and mapping

Measurement Performance

Product Model	LPX-T1M4	Comments
Application Field	Indoor/Outdoor	
Light Source	infrared laser(905nm)	
Laser Safety Level	Class 1	IEC 60825-1:2014
Angular Range	270°	
Scan Rate	20~40Hz	
Angular Resolution	0.12°	20Hz scan rate
Distance Range	0.05~40m	Under 70% reflectivity
Distance Resolution	8mm	All distance range*
Sample Frequency	60,000Hz	
Anti-Ambient Light Ability	80,000 lx	Outdoor Mode

Figure 2-1 LPX Measurement Performance

Note: the TOF range system distance resolution changes along with distance.

Mechanical & Electronic Specification

Product Model	LPX-T1M4	Comments
Electrical Connection	1X Ethernet Interface	4-pin, M12 plug
	1X Power Input Interface	5-pin, M12 plug
Supply Voltage	9~28 VDC	
Power Dissipation	Typ. 4 W	
Cover Color	Mountain Lake Blue	
Cover IP Grade	IP67	
IP Grade	III	IEC 61000-4-2:2009
Weight	264 g	Without cables
Dimension(length*width*height)	60 mm x 73 mm x 85 mm	

Figure 2-2 LPX Mechanical & Electronic Specification

Performance

Product Model	LPX-T1M4	Comments
Recognizable Shape	Almost any shape	
Statistical Error	20 mm ¹⁾	
Integrated Application	Ranging data output	

Figure 2-3 LPX performance

¹⁾ Technical data like ranging error and scanning range is guaranteed to be accurate in 10m scanning range.

Environment Parameters

Product Model	LPX-T1M4	Comments
Object Reflection Rate	4 % ... > 1,000 % (Reflector)	
EMC	EN 55032:2015/ EN 55035:2017	
Anti-vibration Ability	IEC 60068-2-6	
Impact Resistance	IEC 60068-2-27	
Operation Temperature	-20 °C ... +50 °C	
Storage Temperature	-40 °C ... +75 °C	

Figure 2-4 LPX Environment Parameters

Coordinate System Definition of Scanning Data

The LPX-T1 adopts coordinate system of the left hand. The dead ahead of the sensors is the x axis of the coordinate system; the origin is the rotating center of the range scanner core. The rotation angle increases as rotating clockwise. The detailed definition is shown in the following figure:

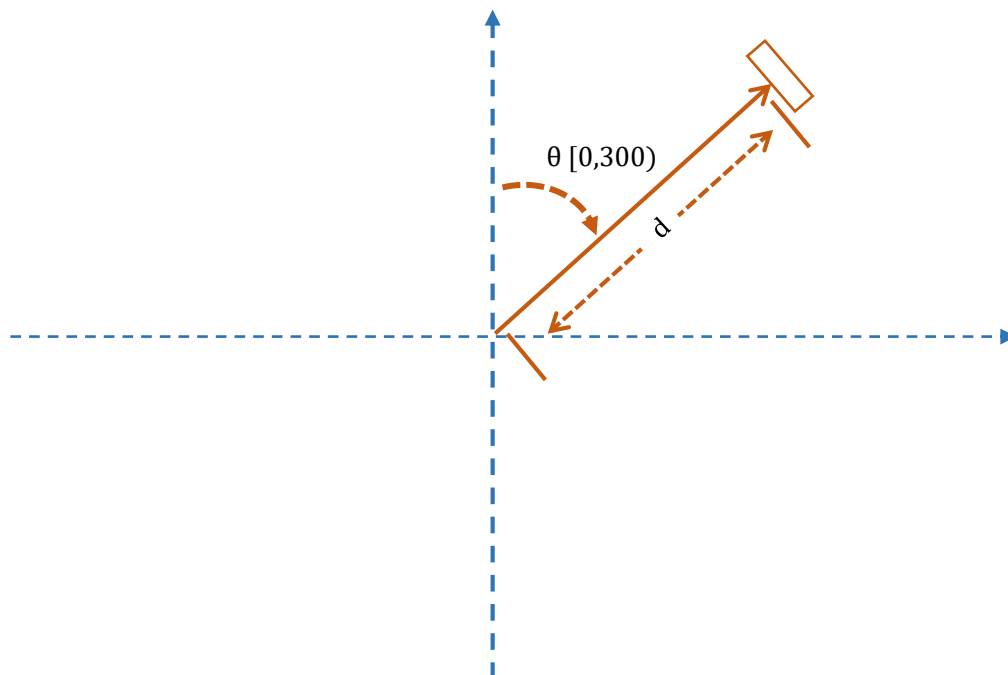
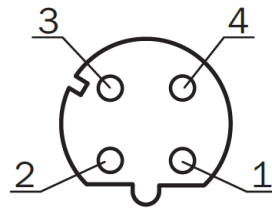

Figure 2-5 LPX Scanning Data Coordinate System Definition

Network interface



Pin	Signal	Type	Description
1	TD+	Output	Sending data+
2	RD+	Input	Receiving data+
3	TD-	Output	Sending data-
4	RD-	Input	Receiving data-

Figure 2-6 LPX Network Interface Definition

Power Supply Interface

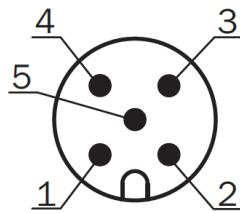

Pin	Signal	Type	Description	Min	Typical	Max
1	VCC	Power Supply	System Power Supply	9V	12V	28V
2	SYNC	Output	Sync Output	0V	3.3V	3.5V
3	GND	Power Supply	GND	0V	0V	0V
4	NA	Reserved	Not for GND or any other circuit			
5	NA	Reserved	Not for GND or any other circuit			

Figure 2-7 LPX Power Supply Definition

Power Supply Interface Specification

LPX-T1 takes the only external power to power the range scanner core and the motor system which make the core rotate. To make the LPX-T1 work normally, the host system needs to ensure the output of the power and meet its requirements of the power supply ripple.

LPX-T1M4	Min	Typical	Max	Remark
Power Supply Voltage	9V	12V	28V	If the voltage exceeds the max value, it may damage the core
System Start Current	-	1200mA	1500mA	12V Power Supply The system startup requires relatively higher current under low voltage.
Working Power Current	-	200mA	220mA	12V Power Supply

Figure 2-8 RPLIDAR Power Supply Specification

Data Communication Interface

The LPX-T1 takes the RJ45 as the communication interface and communicates via ETHERNET UDP. Its communication standard and rate are as below:

Interface	Standard	Rate
Ethernet Network	802.3/802.3u	10/100M

Figure 2-9 LPX Network Interface Specification

Scanner Motor Control

The LPX-T1 is embedded with a motor driver which has speed tuning feature. Users can control the start, the stop and the rotating speed of the LPX-T1 via SDK. For details, please refer to SDK manuals.

To help users improve and speed up the product development based on RPLIDAR, SLAMTEC provides the plug-in Framegrabber in its GUI development tool RobotStudio for debugging and SDK available for x86 Windows, x86 Linux and Arm Linux and etc. Please contact SLAMTEC for detail information.

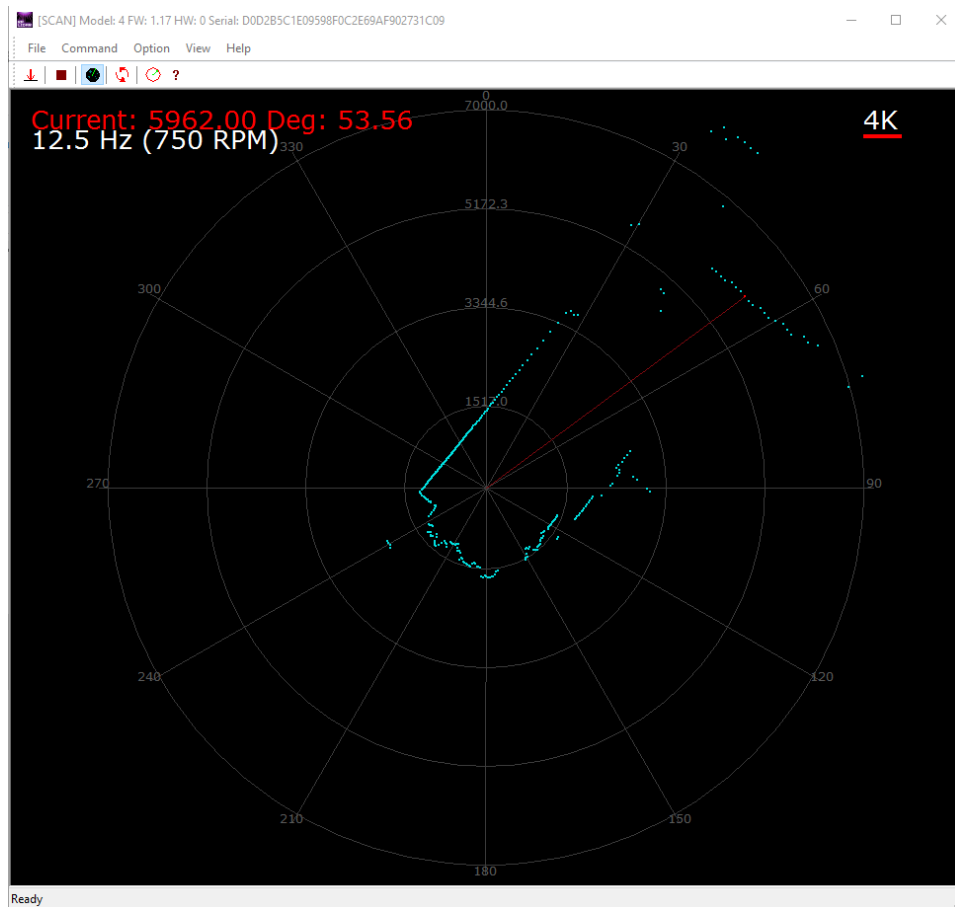
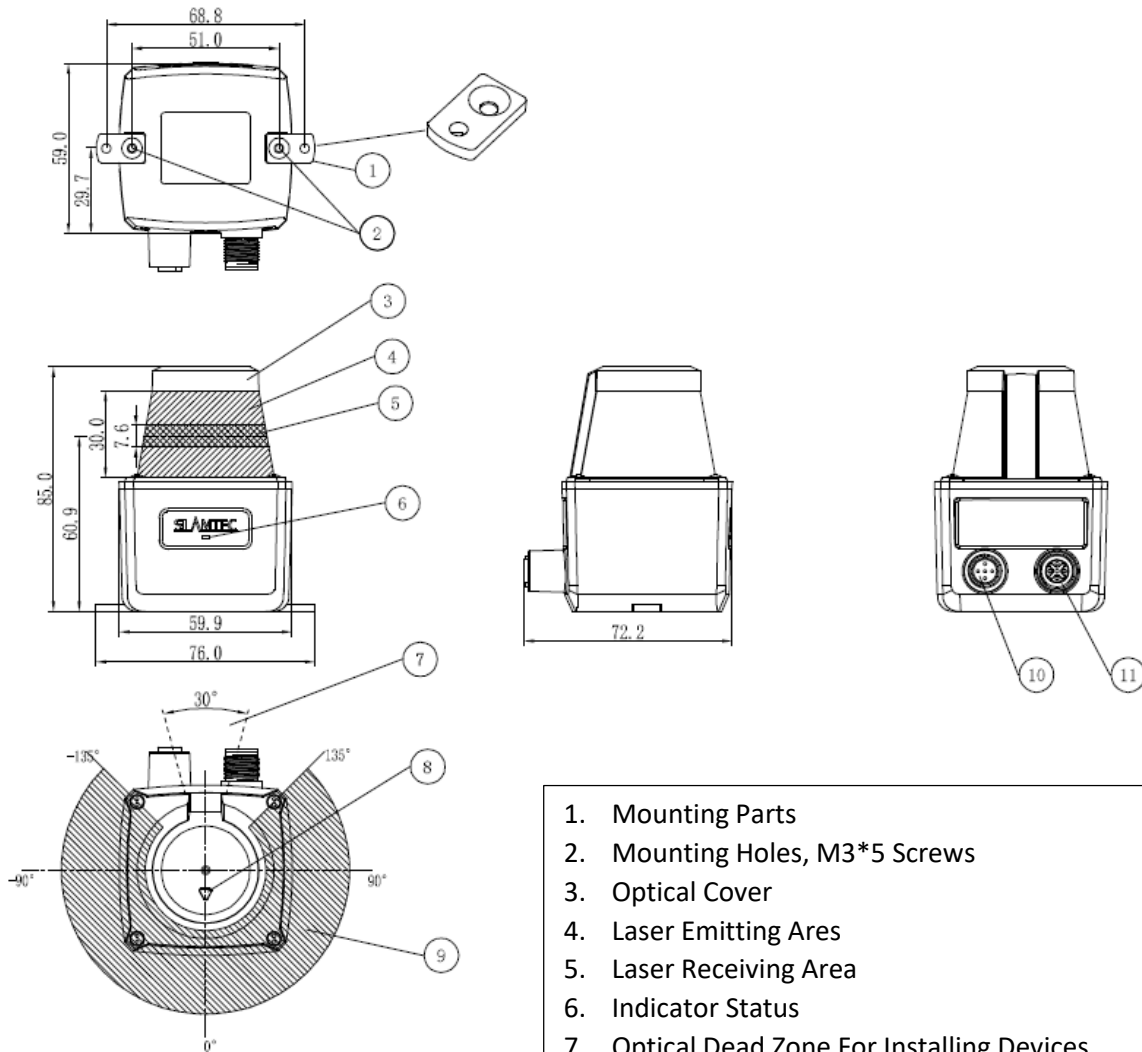

Figure 4-1 The Framegrabber in RoboStudio

The mechanical dimensions of the LPX-T1 are shown as below (unit: mm):

Note: the bottom M3*4 screws for fixing the LPX-T1 should be no longer than 4mm, or they may damage the LPX-T1 parts inside.



- 1. Mounting Parts
- 2. Mounting Holes, M3*5 Screws
- 3. Optical Cover
- 4. Laser Emitting Area
- 5. Laser Receiving Area
- 6. Indicator Status
- 7. Optical Dead Zone For Installing Devices
- 8. Scan Map 0° Direction Mark
- 9. 270° Effective Scan Area
- 10. Power Input Interface, 5-pin, M12 Plug
- 11. Ethernet Output Interface, 4-pin, M12 Plug

Figure 5-1 RPLIDAR Mechanical Dimensions

Date	Version	Description
2020-07-20	V1.0	Initial version for T1M1
2021-12-20	V1.1	Upgrade Sample Rate to 60k
2022-12-10	V1.2	Upgrade Figure 2-1

Image and Table Index

FIGURE 1-1 RPLIDAR SYSTEM COMPOSITION	4
FIGURE 1-2 THE WORKING MECHANISM OF LPX-T1	5
FIGURE 1-3 THE OBTAINED ENVIRONMENT MAP FROM RPLIDAR SCANNING	5
FIGURE 1-4 LPX SAMPLING DATA INFORMATION.....	6
FIGURE 1-5 LPX SAMPLING POINT DATA FRAME	7
FIGURE 2-1 LPX MEASUREMENT PERFORMANCE.....	8
FIGURE 2-2 LPX MECHANICAL & ELECTRONIC SPECIFICATION	8
FIGURE 2-3 LPX PERFORMANCE	9
FIGURE 2-4 LPX ENVIRONMENT PARAMETERS.....	9
FIGURE 2-5 LPX SCANNING DATA COORDINATE SYSTEM DEFINITION	9
FIGURE 2-6 LPX NETWORK INTERFACE DEFINITION.....	10
FIGURE 2-7 LPX POWER SUPPLY DEFINITION	10
FIGURE 2-8 RPLIDAR POWER SUPPLY SPECIFICATION.....	11
FIGURE 2-9 LPX NETWORK INTERFACE SPECIFICATION	11
FIGURE 4-1 THE FRAMEGRABBER IN ROBOSTUDIO	12
FIGURE 5-1 RPLIDAR MECHANICAL DIMENSIONS.....	13