

Hermes Universal Robot Platform

Model: H5M15

Specification

- Suitable for small and medium sized robot development
- Strong Adaptability
- Widely Modifiable



Contents

I. Introduction.....	3
II. Exterior view	4
III. Charging station	4
IV. List of products	4
V. Product parameters.....	5

I. Introduction

Hermes is a compact, adaptive, and cost-effective robot platform developed by SLAMTEC, designed to meet the needs of small robot application development. It can be used in various commercial environments such as intelligent inspection robots, container delivery robots, and restaurant serving robots.

It is equipped with SLAMTEC's newly upgraded high-performance SLAMCUBE2 autonomous navigation and localization system, which enables it to work in various commercial settings with different applications.

Multi-Floor movement and Simple deployment

Hermes is equipped with SLAMTEC's newly upgraded Intelligent Elevator Control System 4.0, which adapts to different elevator deployments from various brands, making it more versatile.

Hermes uses the latest upgraded version of SLAMTEC's RoboStudio 2.0 deployment software, which supports one-click merging of maps for multi-floor mapping. It enhances the mapping and deployment efficiency while streamlining the deployment process, resulting in easy and quick deployment.

Multi-sensor data fusion

Hermes PRO MAX adopts multi-sensor fusion technology, including LiDAR sensor, magnetic sensor, depth camera, collision sensor, etc. This enables it to adapt freely to the complex and changing commercial environment, and successfully achieve autonomous mapping, localization, and navigation.

II. Exterior view

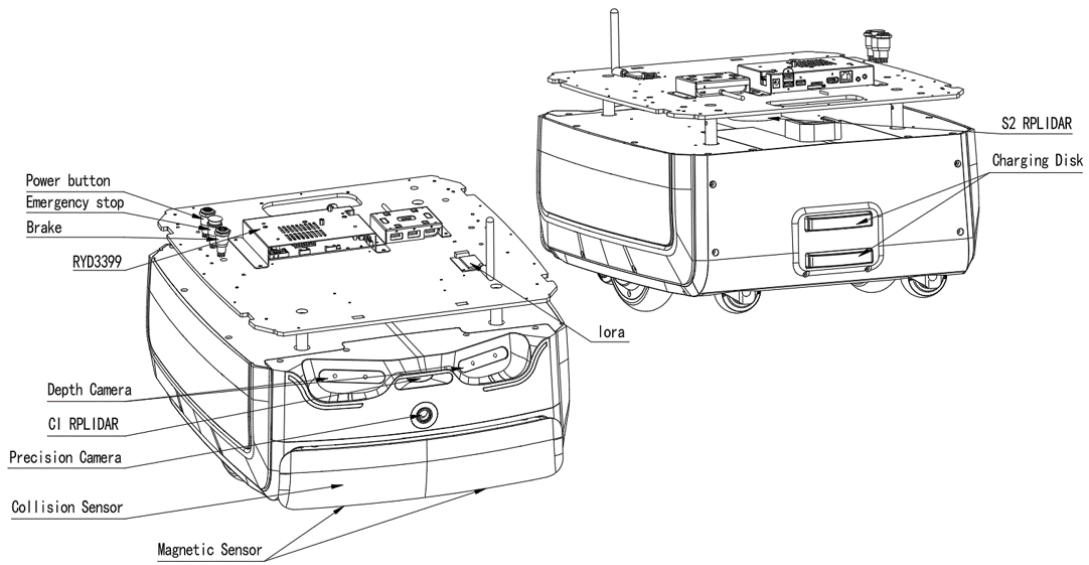

III. Charging station

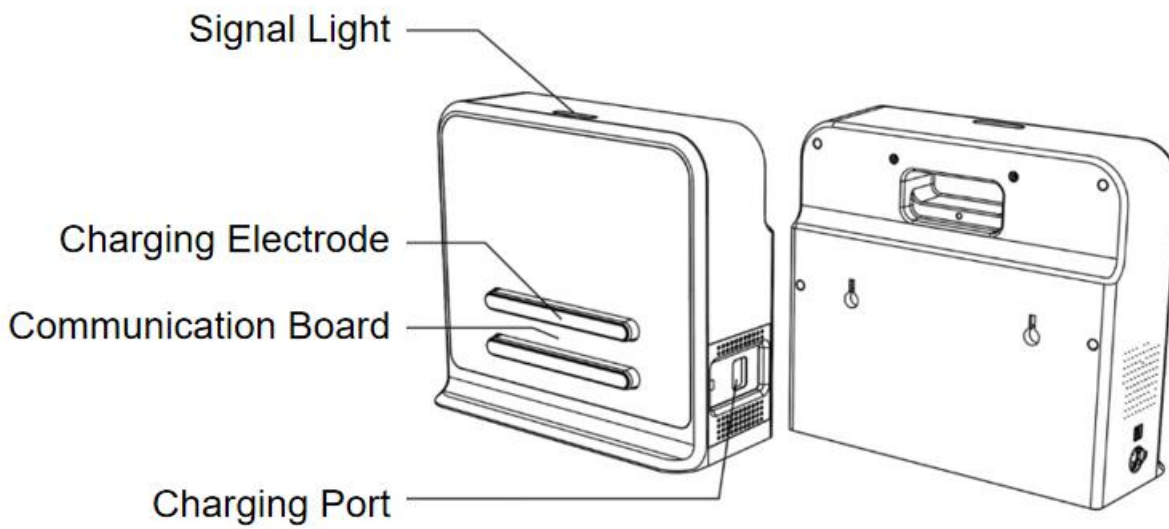

IV. List of products

Description	Quantity	Remark
Hermes	1	Hermes chassis body
Charging station	1	The environment needs to be selected before deployment

V. Product parameters

Model		Hermes Robot Base	
Core Feature		SLAMWARE™ Localization and Navigation	
Features		Metric	Value
Dimension and Weight		Length × Width	465mm*545mm
		Height	276mm (excludes controller)
		Net Weight	40kg
		Rated Load	50kg
		Max Load (Flat Concrete Surface)	80kg
	LIDAR	Model	RPLIDAR S2 (Dtof)
Sensor Performance		Scanning Radius	0.05-30m (90% reflectivity, white objects) 0.05-10m (10% reflectivity, black objects)
		Distance Accuracy	±30mm
		Quantity	2

	Depth Camera	Detection Range	0.3m –2m
		Field of View (FOV)	H:117±3°; V:70±3°
	Low Obstacle & Cliff Detection Sensor	Quantity	1
		Minimum Detection Height for Low Obstacles	>3cm
	Precise Docking of Cameras	Docking Accuracy	±1.5cm
		Docking Angle	±1.0°
	Magnetic Sensor	Quantity	2
		Max Detection Range	35mm
	Bumper	Quantity	2
		Trigger Mode	Physical Collisions
		Detection Range	0.3-0.5cm
		Detectable Minimum Force	8N
	Mapping performance	Map Resolution	50mm
		Max Mapping Area	300m x300m (5cm map resolution)

	Maximum Operating Area	100,000 m ² (5cm map resolution)
Mobility Performance	Maximum Moving speed	1.2m/s (Customizable to 1.5m/s)
	Default Moving Speed	0.7m/s
	Max Cross Slope	10° Slope: Max slope angle of chassis: 10°; Slope = 18% × Ramp; The height of the full-machine mass center is within 18 cm, and the safety ramp within 10°. (A 100% slope means a 45° ramp, whose height difference for 100 m is 100 m.)
	Vertical Crossing Height	2cm (Full-load)
	Horizontal Crossing Width	4cm (Full-load)
	Min Path Width (robot base)	75cm
	Alignment Accuracy (AVG)	±5cm

		Alignment Accuracy (MAX)	$\pm 8\text{cm}$
		Min Point to Point Angle	$\pm 3.0^\circ$
		Multi-Robots Obstacles Avoidance	Supports up to 3 robots in the same scene
			LORA Module (Standard)
Wheelset		Wheelset Parameters	7NM 6.5 Inch In-Wheel- Motor*2 2.5 Inch Industrial Universal Wheel*2; 3 Inch Auxiliary Wheel*2 (Front)
User Interface	Hardware Interface	Power Connector	DC 24V 10A
		4G	Support 4G module (paid customization)
		HDMI	1*HDMI
		Audio	1 x 3.5mm headset socket
	1 x LINE_OUT audio jack		
Network Interface	Ethernet	Ethernet; 1*RJ45 Gigabit Ethernet port	

		Wi-Fi	2.4GHz/5GHz
	Software Interface	SLAMWARE™	SDK2.0 HTTP APIs support different programming languages and platforms, such as Windows, iOS, Android, and Linux
Ethernet		Wi-Fi	Network environment without authentication
		4G	Supports 4G SIM cards from domestic and international carriers (customized according to needs)
Battery and Capacity		Capacity Specification	24V 20AH (Lithium Iron Phosphate Battery)
		No-load Operating Time	>10H (No-load, Ambient Temperature Environment)
		Full-load Operating Time	8H(80KG, Ambient Temperature Environment)
		Charging Time	3~3.5h

	Battery Life	2000times
Power Consumption	Standby Power Consumption	32W(No-load)
	Full-load Rated Power Consumption (80kg)	62W (Full-load)
	Max Power Consumption with External Load	240W
Noise	Operating Noise Level	≤60db
Operating Environment	Operating Temperature	0°C ~ 40°C
	Transport and Storage Temperature	-25-+55°C
	Operating Humidity	20 ~ 90%rh
	Operating Altitude	≤2000m

Charging station	
Overall Dimensions	W360mm*D150mm*H320mm
Color	White
Rated Input	100-240V 50/60Hz 3A MAX
Rated output	DC 25.5V 6A

