

Chassis Micro-customization Guide

SLAMTEC's self-developed HERMES, Athena2.0 and APOLLO chassis can meet the needs of small and medium sized robot development, such as delivery robots, inspection robots, concierge robots etc. The chassis is equipped with LIDAR, magnetic sensors, depth cameras, collision sensors, etc., using multi-sensor data fusion technology to improve the robot's system sensing capacity.

In order to meet the needs of our customers, Slamtec offers components such as IPC, ultrasonic sensors, depth cameras, 4G modules, etc.

I. Description of optional parts

1.1 A68TK-204S Industrial PC

A68TK-204S is a low-power industrial computer based on Intel Apollo Lake processing platform with Intel Celeron J3455 processor. It supports single DDR3L laptop memory expansion and single mSATA SSD storage expansion. The product has HDMI, USB and serial interfaces, and is designed for embedded industrial control applications.

The industrial computer is manufactured with aluminum heat dissipation upper shell and metal sheet lower shell, and the surface of the metal sheet is coated by black fine sand baking paint. The device is compact and exquisite. It adopts 12V/24V DC power supply, and the power consumption does not exceed 15W.

1.1.1 Specification information

Device parameters	
Processor	Intel Celeron J3455 Quad-core 1.5~2.3GHz
Memory	4GB DDR3L-1600MT/s
Storage	64GB SSD MSATA
Network	2 GB Ethernet ports (Intel I211AT)
Extended Features	
IO Interface	1 HDMI 1.4b (maximum resolution output: 3840×2160@30Hz)

	2 RJ45 GB Ethernet ports
	4 USB 3.0 ports
	1 LINE-OUT, 1 MIC-IN
Expansion Slot	1 mini-PCIe expansion slot (expandable WIFI/4G module)
Device Features	
Operating System	Windows/Linux/Unix
Power Supply	12V power supply
Size Specification	
Chassis size	148mm (L) × 106mm (W) × 50mm (H)
Operating Environment	
Temperature	Operating temperature: -10°C~+50°C Storage temperature: -20°C~+85°C
Relative Humidity	Under non-operating environment 95%, non-condensing between 25°C to 30°C

1.1.2 Introduction of the device



Side view of IPC



IPC IO rear view



IPC IO front view

1.1.3 Structural Dimensions

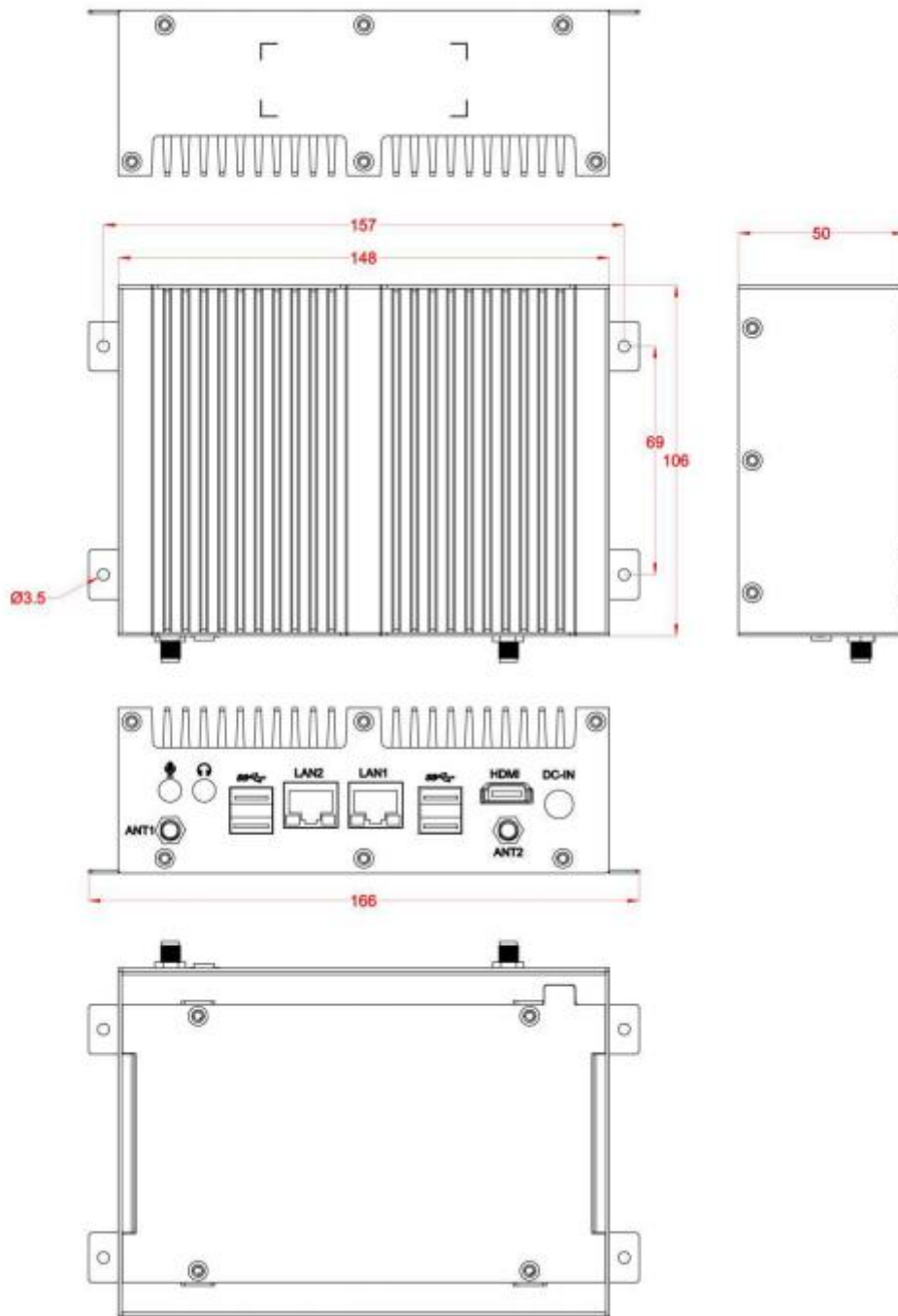

Note: The en route dimensions are in mm.

1.1.4 Interface Introduction

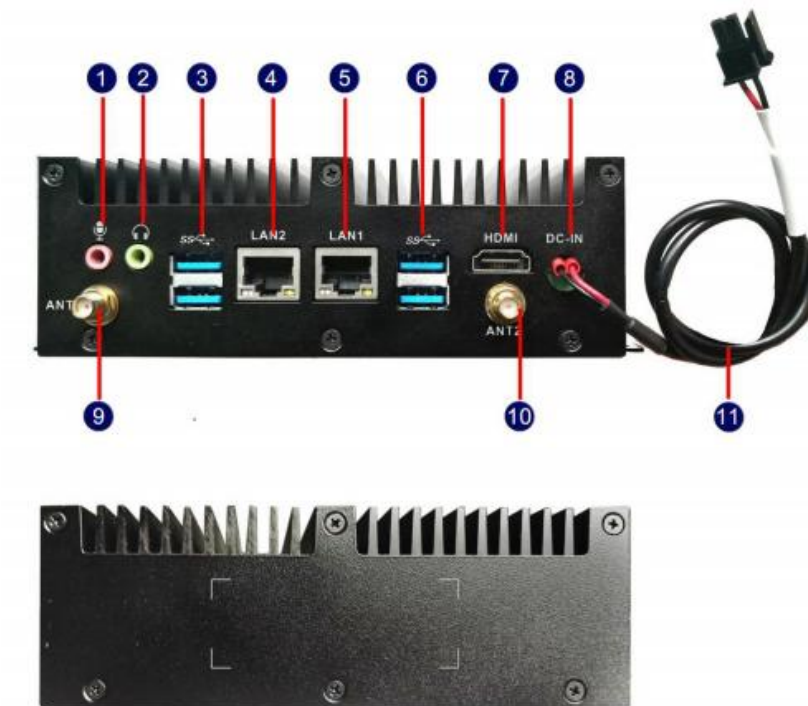

Interface Diagram

Interface Description

- ① 3.5mm MIC-IN audio jack
- ② 3.5mm LINE-OUT audio jack
- ③ Standard dual-layer USB3.0 Type-A
- ④ RJ45 GB LAN port LAN2
- ⑤ RJ45 GB LAN1
- ⑥ Standard dual-layer USB3.0 Type-A
- ⑦ HDMI display output
- ⑧ Power input connector (wiring hole)
- ⑨ WIFI antenna extension 1
- ⑩ WIFI antenna extension 2
- ⑪ Power supply extension cable

1.2 Depth Cameras

A31R50 products, mainly integrated with large angle VCSEL projector, dual IR 940nm single-pass large angle global exposure sensor module, optional IMU, RGB camera and distance sensor. The front camera is covered with glass, through the USB2.0 interface to adapt to a variety of backend system, it supports Linux, ROS, Android, Windows system. It is designed for low-cost solutions to provide RGBD depth point cloud information, providing technical support for composition, positioning and obstacle avoidance.

1.2.1 Specification

Items	Description
Processor	Ai3101 High Performance ASIC Chip
Distance Recognition	0.3-3.5m
FOV	H75°Earth3°, V51°Earth3°
Color Sensor	1080P RGB image sensor, H88.2,V56.8,D96.2, distortion <=1.5%, f/2.0, fixed focus
Power input	5VDC
Power consumption	<2W
Operating temperature	-5-50℃
Operating humidity	≤90%
Storage temperature	-30℃~+70℃
Storage humidity	90%
Interface	Support USB2.0
Physical Characteristics	Material size with case: 90mm *25mm * 25mm, Weight approx 62g, Pro approx 65g

1.2.2 Product Image



1.2.3 Product dimension drawing

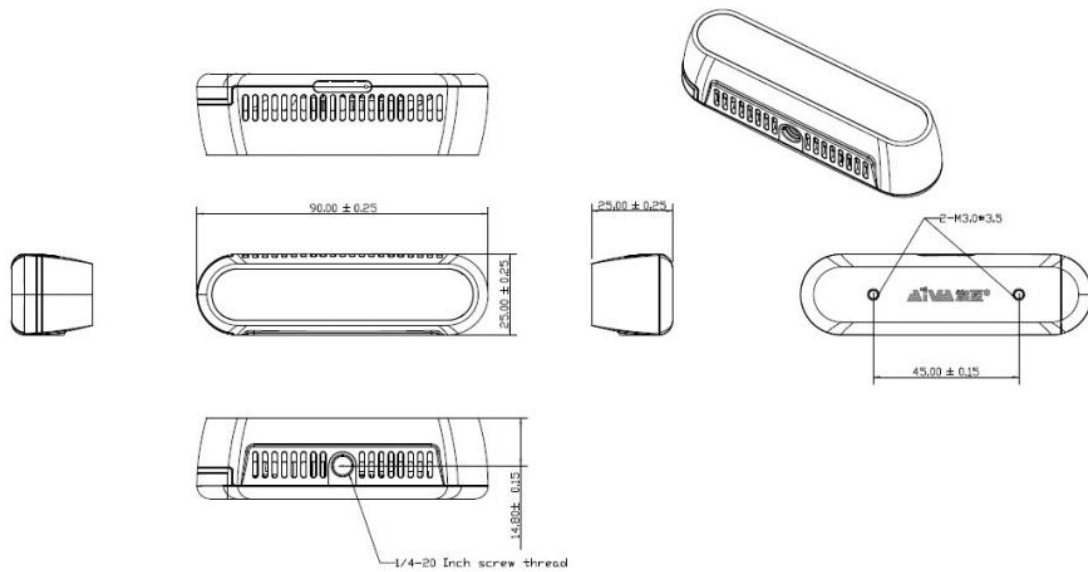

1.3 Ultrasonic sensors

1.3.1 Specifications

Parameter Name	Remarks	Minimum value	Average Value	Maximum value	Unit
Operating Voltage		3.0		5.5	V
5V operating current	Vcc=5V		2.8		mA
3.3V operating current	Vcc=3.3V		2.2		mA
5V Minimum detection distance	Vcc=5V		1	1.5	cm
3.3V Minimum detection distance	Vcc=3.3V		1	1.5	cm
5V Maximum detection distance	Vcc=5V	450	500	650	cm
3.3V Maximum detection distance	Vcc=3.3V	400	450	500	cm
Detection angle				20	°

Detection accuracy			1		%
Resolution			1		Mm
Output method			GPIO		
Operating temperature		-20		80	°C

1.3.2 Physical image



1.3.3 Interface Definition



Vcc、 Trig (控制端)、 Echo (接收端)、 Gnd

1.3.4 Dimension

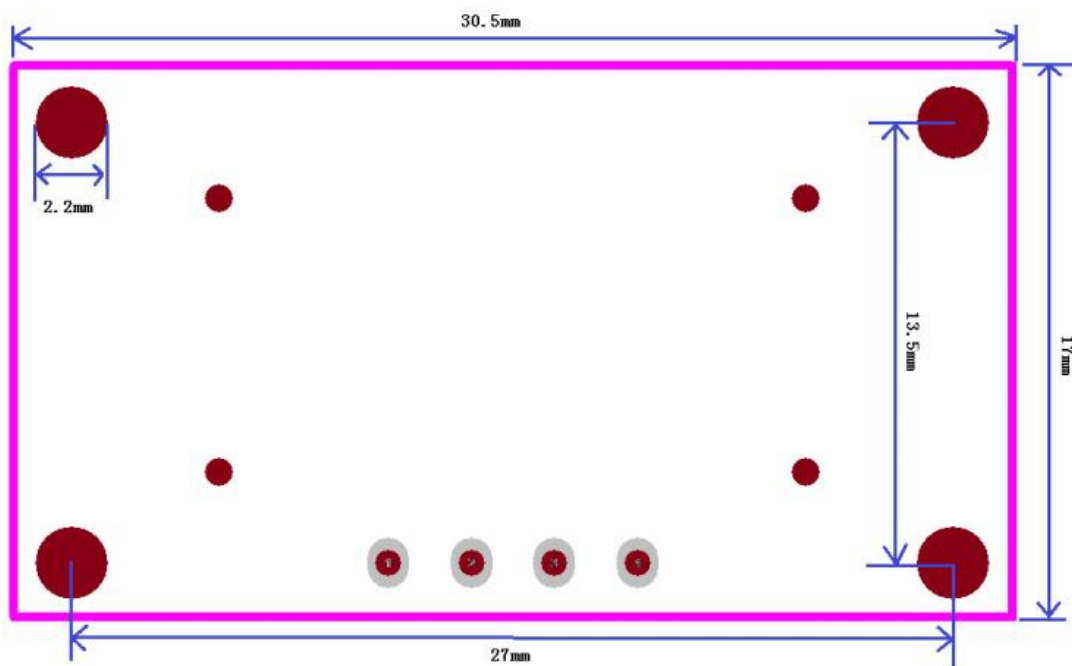

1.3.5 Module working principle

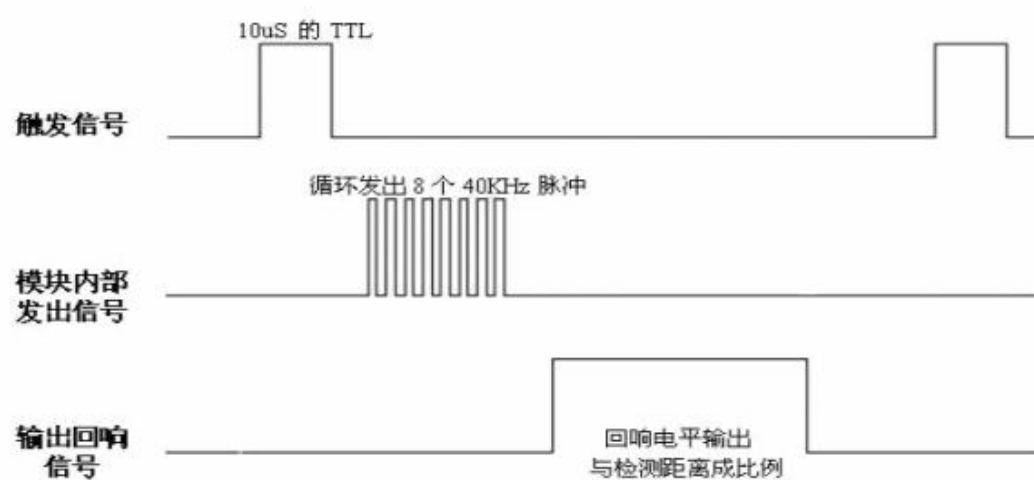

Ultrasonic Timing Chart

- (1) Using IO trigger ranging, give at least 10us high level signal, the actual 40-50uS effect will be better.
- (2) The module automatically sends 8 waves of 40khz.
- (3) There is a signal return, through the IO output a high level, the high level duration is the ultrasonic wave from the emission to return time.
- (4) Test distance = (high level time * speed of sound (340M/S))/2.

1.3.6 Cautions

- (1) This module should not be connected with power. If it is to be connected with power, let the Gnd end of the module be connected first. Otherwise, it will affect the module's operation.
- (2) When measuring the distance, the measured object area is at least 0.5 square meters and should be as flat as possible. Otherwise, it will affect the test results.
- (3) If the test surface is not very regular or when testing distant objects, multiple measurements can be used to calibrate.