

SLAMTEC

Athena 2.0

General Purpose Robot Platform

Model: N5M42-R2TPL

User Manual

- Small- to medium-sized robot development
- Highly adaptable and scalable
- Powerful optional functions

[Learn more >](#)



Shanghai Slamtec Co., Ltd.

Table of Contents

1. PRODUCT OVERVIEW	3
1.1 INTRODUCTION	3
1.2 BASIC FUNCTIONS	3
1.3 EXTERIOR.....	5
1.4 CHARGING DOCK	6
1.5 PRODUCT LIST	6
2.PRODUCT PARAMETERS	7
3. INSTRUCTIONS OF HARDWARE.....	10
3.1 WIRE INSTRUCTIONS	10
3.2 IMPORTANT INTERFACES OF DEVELOPING BOARD ON RK3399	13
3.3 REFERENCE OF HARDWARE DESIGN.....	13
4. REFERENCE OF STRUCTURE DESIGN.....	24
4.1 INSTALLING INTERFACE OF HOST COMPUTER	24
4.2 INSTRUCTION OF LOAD LIMIT	24
4.3 RADAR CLEARANCE AREA	25
4.4 DEEP CAMERA CLEARANCE AREA.....	26
5. SETUP INSTRUCTIONS	27
5.1 OPENING	27
5.2 PLACING CHARGING BASE	27
5.3 POWER ON/OFF.....	28
5.4 CHARGING	28
5.5 EMERGENCY STOP & BRAKE AND RESET	28
5.6. CONNECTION TO COMPUTER	29
5.7 MAP BUILDING AND UPLOAD.....	31
5.8 HOST COMPUTER COMPLETES STARTUP AND LOADING THE MAP	34
6. ADJUSTING TOOLS	36
6.1 ROBOSTUDIO	36
6.2 WEB MANAGEMENT BACKSTAGE	36

7. DEVELOPER TOOLS.....	37
7.1 START USING	37
7.2 INTER-SYSTEM ADJUSTING FRAMEWORK.....	37
7.3 INSTRUCTIONS OF EACH SYSTEM.....	37
7.4 DEMONSTRATIONS OF CODE	38
7.5 DETAILS OF ROBOT API	39
8. INTRODUCTION AND USE OF ELEVATOR CONTROL	42
8.1 INTRODUCTION.....	42
8.2 FEATURES	42
9. SPECIAL NOTE	44
9.1 CHARGE POINT DEPLOYMENT	44
9.2 RESTRICTED USAGE SCENARIOS	44
9.3 FAULTS THAT CANNOT BE HANDLED TEMPORARILY	45
9.4 NOTES	45
10. MAINTENANCE.....	47
11. COMMON FAULTS AND TROUBLESHOOTING.....	48
12. CERTIFICATE	48

1. Product Overview

1.1 Introduction

Developed by Slamtec, Athena 2.0 is a scalable and low-cost robot platform capable of meeting the needs of small-sized robot application development in areas such as smart patrol robots, container transportation robots, food delivery robots, and more.

The built-in SLAMCUBE 2 autonomous localization and navigation system enables path-finding and localization and navigation features, making Athena 2.0 capable of performing a variety of tasks across different commercial environments.

Cross-floor Moving, Light Deployment

Athena 2.0 is equipped with the latest version of Slamtec Smart Elevator Control 4.0, which allows it to adapt to different brands of elevators.

Through the latest version of Slamtec RoboStudio 2.0, Athena 2.0 supports integration of maps of multiple floors in one click. This improves the mapping efficiency and streamlines the deployment, thus enabling light deployment and fast use.

Multi-Sensor Data Fusion

Athena 2.0 uses multi-sensor data fusion technology. Fitted with equipment such as lidar, magnetic sensors, depth cameras, and bumper sensors, Athena 2.0 can implement autonomous mapping, localization, and navigation by flexibly responding to complex and ever-changing operational environments.

1.2 Basic Functions

1.2.1 Compact and Flexible

Athena 2.0 can move flexibly in a small size, thus meeting the needs of flexible moving and deployment-free scenarios. Thanks to its high obstacle passing stability, Athena 2.0 can easily pass narrow aisles and ramps.

1.2.2 Cross-floor Delivery and Light Deployment

Athena 2.0 is equipped with the latest version of Slamtec Smart Elevator Control 4.0, which allows it to adapt to different brands of elevators. When combined with RoboStudio 2.0, it can effectively enable light deployment and fast use.

Smart Elevator Control 4.0 addresses the challenges of bad weather, as well as unstable air pressure and communication in high-rise buildings. It provides accurate detection of elevator statuses along with call-control functionality. For hotel/restaurant delivery robots, it provides efficient and reliable solutions that help them autonomously navigate elevators in cross-floor scenarios.

1.2.3 Autonomous Mapping, Localization and Navigation

Athena 2.0 is built with the latest version of Slamtec SLAMCUBE 2 autonomous localization and navigation system which is more stable and can accommodate more interfaces. The

structural design integrated three boxes into one, saving more space for chassis layout. With the path-finding, autonomous mapping and localization and navigation features, it helps robots figure out where they are, where they should go, and the best way to get there. It enables the robots to automatically find paths, locate, and move as needed without human assistance. In addition, Athena 2.0 supports multi-route patrol mode.

1.2.4 Rich Port Options and High Scalability

Athena 2.0 owns a completely open hardware and software platform and supports extended hardware. The rich port options eliminate the restrictions in development platform and programming language, which makes Athena 2.0 universal for all types of host computer and support development of business logic applications through SLAMWARE SDK.

1.2.5 360° Protection and Smart Obstacle Avoidance

Athena 2.0 is fitted with equipment such as lidar, magnetic sensors, depth cameras, and bumper sensors, and adopts the multi-sensor fusion technology. It provides rapid and accurate identification of surrounding active environments, enabling smart obstacle avoidance and greatly reducing the chances of safety incidents. It also has fall-resistant and collision-resistant protection and emergency stop features, making the food delivery process fully protected, secure, and reliable.

1.2.6 Autonomous Recharging

The autonomous recharging feature ensures that Athena 2.0 will have enough power to complete the assigned tasks. Athena 2.0 will return automatically to its charging station when its remaining power falls below the set limits.

Special note: the automatic recharge function cannot be triggered only under the condition of that combined with upper machine with delivery and disinfection plug-in or customized models.

1.2.7 Multi-robot Scheduling & Collaboration

In scenarios such as large hotels, office buildings, and malls, multiple robots will avoid each other according to the task priority when they meet. The collaboration of multiple robots can further improve the delivery and guide efficiency.

Athena 2.0 supports local area network (LAN) and cloud platform collaborative operations, along with the dynamic adjustment of both speed and delivery routes in accordance with the environment to realize efficient, safe, and reliable multi-point delivery.

1.3 Exterior

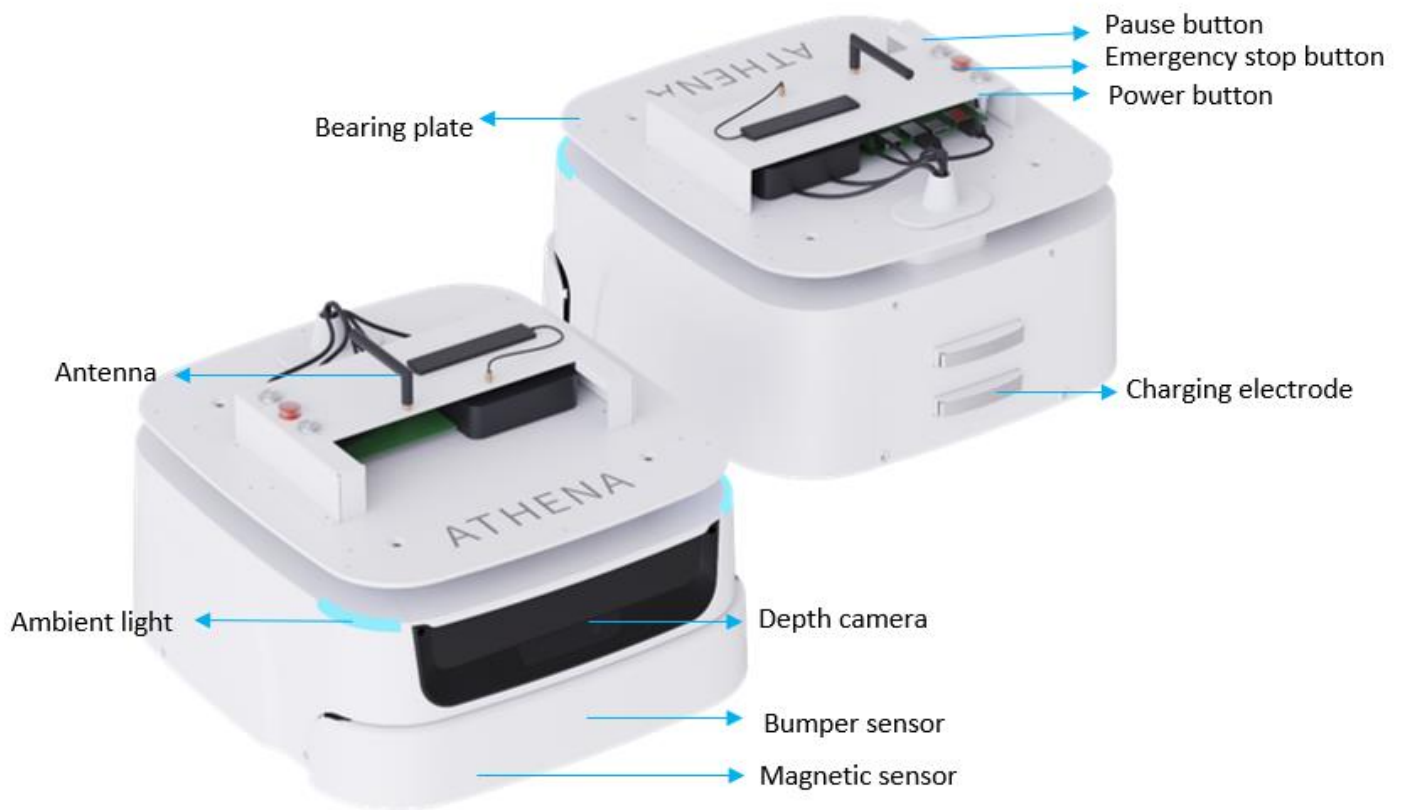

1.4 Charging Dock

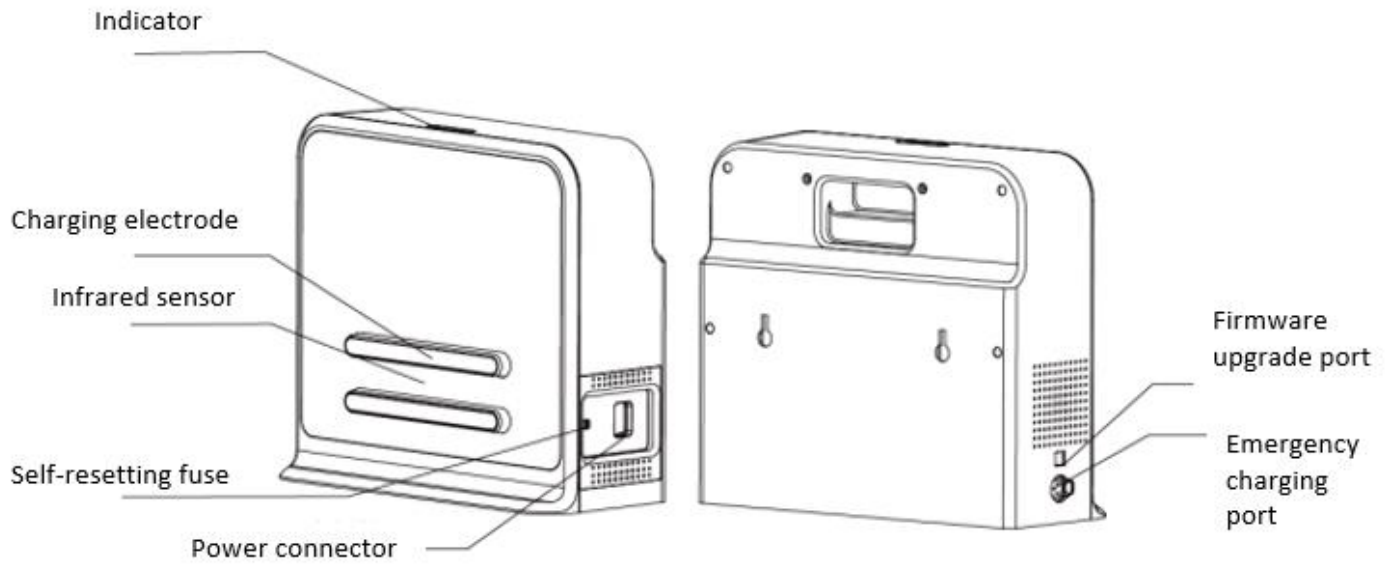

Charging dock diagram

1.5 Product List

Name	Quantity	Notes
Athena 2.0 body	1	Athena 2.0 chassis body
Charging dock	1	Select environment for deployment before use.

2.Product Parameters

Name		Athena 2.0 chassis	
Core feature		SLAMCUBE 2 localization and navigation	
Mass and volume		Length x width	460*428 mm, rotation diameter 551 mm
		Height	232mm (excludes controller)
		Weight	22 kg
		Rated load	40 kg
		Max load (parallel cement pavement)	60kg
Sensor performance parameters	Lidar sensor	Max scan radius (90% surface reflective rate)	30 m (TOF S2 radar)
	Depth camera sensor	Quantity	1 for standard configuration (2 can be customized)
		Detection range	0.3–3.5 m (changed by the condition of illumination)
		Field of View (FOV)	H:75±3°; V:51±3°
	Physical magnetic sensor	Quantity	2 units
		Max detection range	3.5 cm
	Bumper	Quantity	2 units
		Trigger method	Physical collision
Mapping performance		Map resolution	5 cm
		Max mapping area	500m×500m
Motion parameters		Max move speed	1.0 m/s (1.2 m/s can be customized)
		Max cross slope	10° Ramp: Max slope angle of chassis: 10°; Slope =18%*Ramp; The height of the full-machine mass center is within 18 cm, and the safety ramp within 10°. (A 100% slope means a 45° ramp, whose height difference for 100 m is 100 m.)
		Passing obstacle height	2 cm
		Passing obstacle width	4 cm
		Min pass range	55 cm
		Motor	Wheelset





			wheel
User port	Hardware port	Ethernet	1x RJ45 Gigabit Ethernet port
		Power connector	DC 24V 9.5A
			DC 12V 2A
		Wi-Fi	2.4 GHz
		HDMI	1x HDMI
		Audio	1x 3.5mm headset socket
	1x LINE_MIC audio jack (Co-lay with headset socket)		
	1x Dual-channel 5w/8Ω amplifier jack		
Type-C	Standard USB 3.0 Type-C port		
Software API	SLAMWARE™	HTTP API, supports different development languages and platforms, such as Windows, iOS, Android, and Linux	
Battery and capacity		Capacity specifications	18 AH (standard)
			Battery scalable to 90 AH
		No-load operating time	19h (no load)
		Full-load operating time	8h (full load)
		Charging time	3-4 h (standard charging station)
		Battery life	500 charges
Power consumption		Power dissipation in standby time	17W (no load)
		Full-load rated power consumption (full load weight: 40kg)	40W (moving)
		Max power consumption with external load	228W
		Rated output	25.2V 2A
Noise		Operating noise	≤ 60 db
Operating environment		Operating temperature	0°C–40°C
		Transport and storage temperature	-25°C to +55°C
		Operating humidity	30%–70%RH (No condensation)
		Applicable altitude	≤ 2000 m





Charging station

Charging station	
Size	360 mm*150 mm*320 mm (W*D*H)
Color	White
Rated input	100-240V 50/60 Hz 3A Max
Rated output	DC 25.5V 6A

3. Instructions Of Hardware

3.1 Wire Instructions

Interfaces	Picture	Index	Function	Note
Power ON/OFF		--	Power switch of the entire system. Short press until the indicator light turns on power-on, long press until the indicator light turns off power-off.	--
Shut Down		--	Effectively control Athena2.0 in an emergency. After pressing, Athena2.0 will immediately shut down.	It is a switch that must be designed according to rigid regulations. If the switch is not designed, Athena2.0 will refuse to run.
Brake		--	When robot is energized, press this switch to release the brake and you can push the robot freely; press it once again to brake, and the robot will not be able to push it freely.	Invalid if the robot is not turned on
24V Power		Rated Voltage 24V Maximum current 9.5A	Maximum output power is 200W, can be used to supply power to external devices	No overload
12V RK3399 Power Supply Wire		Rated Voltage 12V Maximum Current 20A	Cube2 supplies power to the RK3399 development board.	

Depth Camera Interface		USB3.0	Connected to the RK3399 development via USB3.0 to obtain information.	Need to pay attention to the left and right sequence.
Docking Camera		USB2.0	Connected to the RK3399 development via USB3.0 to obtain information of code scanning camera.	Assist precise docking.
12V -DISP		Rated Voltage 12V (See the figure below for the design drawings)	12V working power of Cube2 to provide the external display screen of human-computer interaction.	Maximum current 2A
USB-Type-C		USB3.0	Used for communication between 3399 and Cube2.	Connect to Hub3.0

Design drawing of 12V -DISP terminal

ECN NO.	REV	REVISIONS DESCRIPTION	APPVD	DATE
	A/0	INITIAL RELEASE	*****	2021.06.08

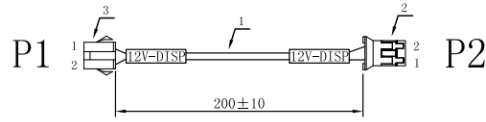

接线表

颜色	P1	P2
红	1	2
黑	2	1

产品符合RoHS要求
This product conforms RoHS environmental requirements

上海思岚科技有限公司 Shanghai SLAMTEC Co., Ltd.

①										
②										
③										
④										
⑤										
⑥										
⑦										
⑧										
⑨	SI-2P		1	PCS						
⑩	PI-2Y		1	PCS						
⑪	UL1007 22AWG		1	PCS						
序号 NO.	材料规格 SREC		用量 QTY	单位 UNIT	备注	核准 APPROVED	版次 REV.	A/0	比例 SCALE	FREE

思岚料号 P/N		产品名称 TITLE	12V-DISP
图号 DWG NO.	Mry2-L04-003	外部料号 P/N	
制图 DRAWN		视图 VIEW	
审核 CHECK		页次 SHEET	1 of 1
		单位 UNIT	mm
		比例 SCALE	FREE
		公差 TOLERANCE	X ±0.5 X.X ±0.3 X.XX ±0.1 X.XXX ±0.05 X' ±2" X.X' ±1"

3.2 Important Interfaces of Developing Board on RK3399

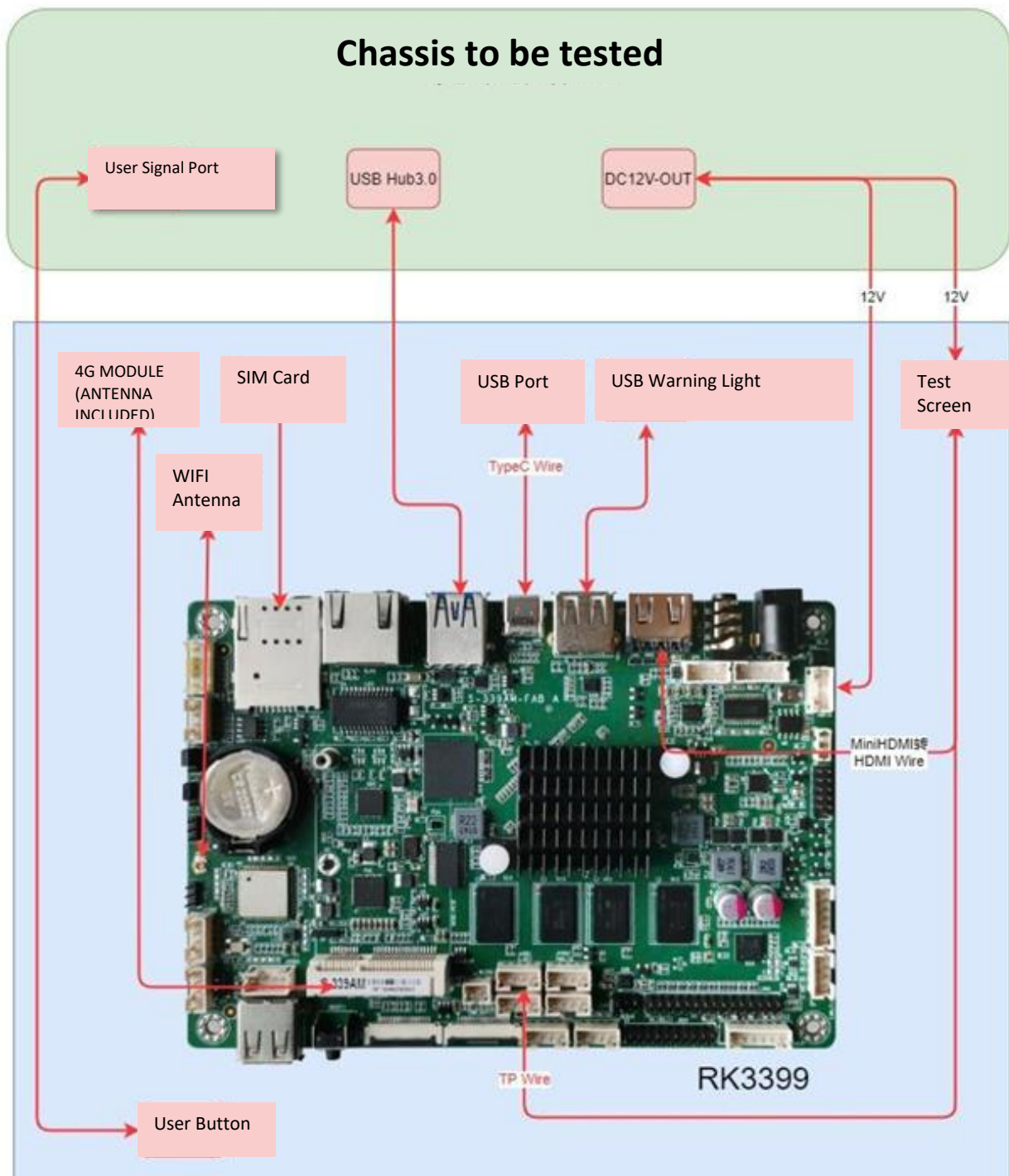

3.3 Reference of Hardware Design

Notice:

- (1) Before starting, please read the manual carefully to avoid product damage caused by misoperation;
- (2) The working temperature of the main board is 0°C to +40°C, 30%-70%RH, in order not to damage the product due to excessive cold/heat or moisture;

(3) Do not make strong mechanical movement of this product, and operate this product before static protection is done;

(4) Please turn off the power before installing any external cards or modules;

(5) Please ensure the external power supply is DC 12V to avoid damage to the main board;

3.3.1 Product Description

RK3399 Android system main board adopts Rockchip RK3399 main control solution. The specification of the main board is a standard 3.5-inch structure with a size of 146*102mm.

The main board processing core RK3399 is based on the dual Cortex-A72+four Cortex-A53 core CPU structure. It uses the powerful Mali-T864 GPU graphics display core, supports VP9, H.265/H264 hardware decoding, and 4K ultra high-definition output.

Onboard 4GB DDR3 memory and 32GB storage.

The display interfaces are: 1*HDMI, supporting dual-screen display, which can meet the needs of flexible and diverse point-screen applications.

The board has a 3.5mm headset socket and a dual-channel 5W power amplifier speaker interface, which can meet the needs of audio applications.

The main board integrates a gigabit network port, and also integrates a WIFI/Bluetooth module to support various network access methods.

The onboard Mini-PCIe expansion slot supports 4G network card module expansion.

The main board has 5 USB ports and 1 Type-C slot, 2 serial slots, and 1 set of 8 GPIO pins. In addition, the main board has a rich function expansion pin interface.

The main board uses a single 12V DC adapter for power supply.

Characteristics of Main Board:

- ★Based on Rockchip RK3399 ARM processor solution;
- ★Display interfaces: eDP and HDMI;
- ★Hardware decoding H.265 high-definition video, support 4K ultra high-definition output;
- ★Rich functions, onboard 5*USB/2*COM/8*GPIO/1*IR infrared;

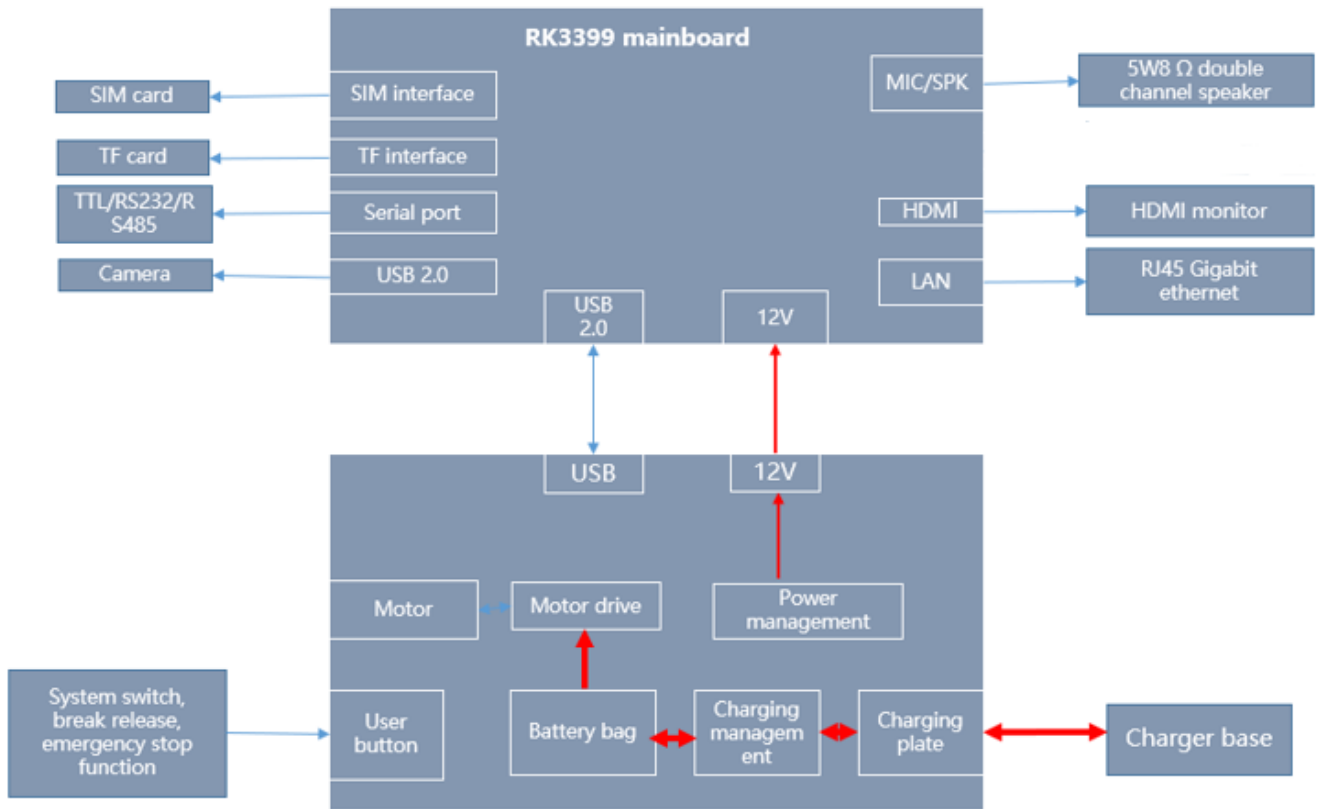

6-1 RK3399 Main board basic application diagram

3.3.2 Product specifications

(1) Hardware Specification Sheet

Processor	Rockchip RK3399 ①
RAM	4GB DDR3
Display	1*eDP 1*HDMI output supports 480p/480i/576p/576i/720p/1080p/1080i/4k
Internet	1*RJ45 Gigabit Ethernet 1*WIFI+Bluetooth ③
Audio	1*3.5mm headset socket 1*LINE_MIC audio pin (with headset socket Co-lay) 1*Dual-channel 5w/8Ω power amplifier speaker pin
Storage	32GB eMMC
COM	2* serial port ④
Others	4*USB2.0、1*USB3.0、1*USB3.0 Type-C OTG; 1* standard Mini-PCIE slot, for 4G module 1*TF card extension ⑤ 8 GPIO pin 1*IR infrared extension pin 1*I2C touch screen extension pin 2 A/D conversion pin

	2*MIPI-CSI2 camera expansion port 1*G-Sensor gravity sensor
Power connector	DC2.5*5.5 socket/PH2.0-4pin, 12V DC input
Main board specifications	146*102*22mm, green
Operating system	Android 7.1
Working environment	Temperature: 0~+40°C Humidity: 30~70%RH

Remark:

- ① RK3399 is dual-core Cortex-A72 (the highest frequency is 1.8GHz) + 4-core Cortex-A53 (the highest frequency is 1.4GHz);
- ② WIFI specifications: 802.11b/n/g @ 2.4GHz; Bluetooth specifications: Bluetooth 4.0;
- ③ COM1 is the Debug interface and supports TTL/RS232, COM2 can communicate with the onboard MCU, and can also be used as an external RS232/RS485 interface;
- ④ TF card supports maximum expansion to 128GB.

(2) Size of main board

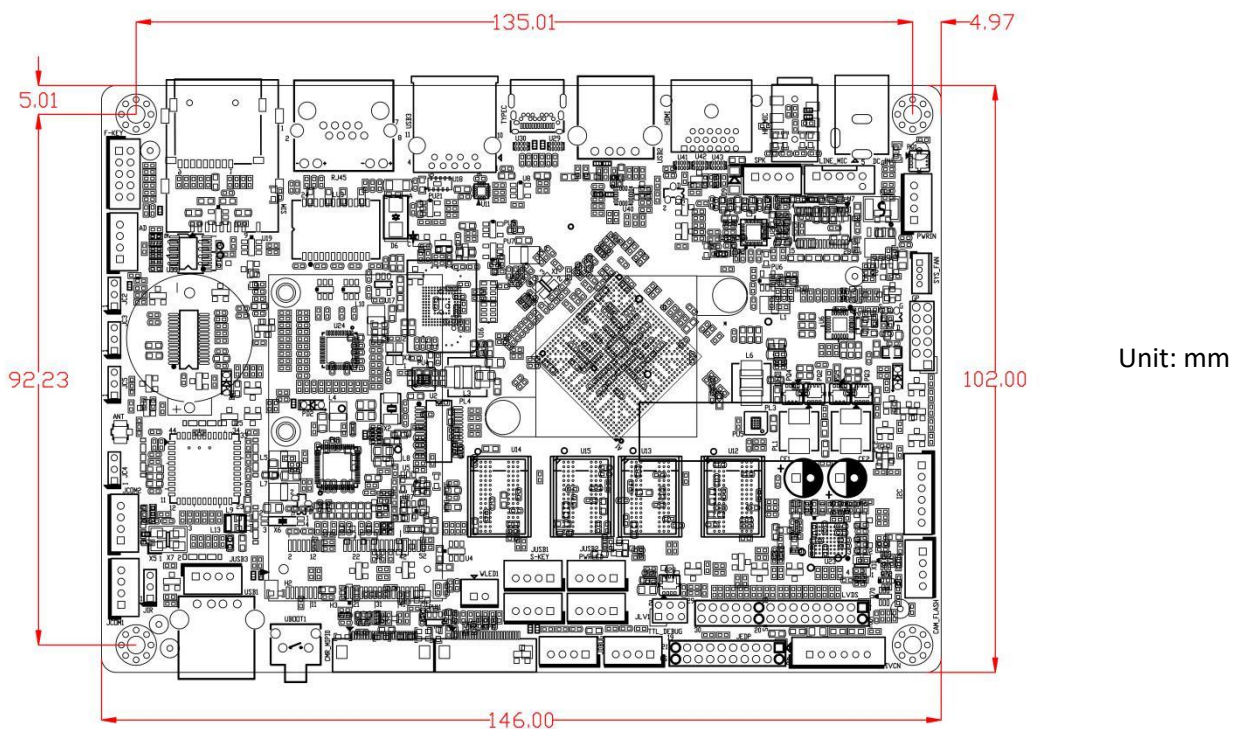

3.3.3 Introduction of Interfaces

(1) Front view of main board

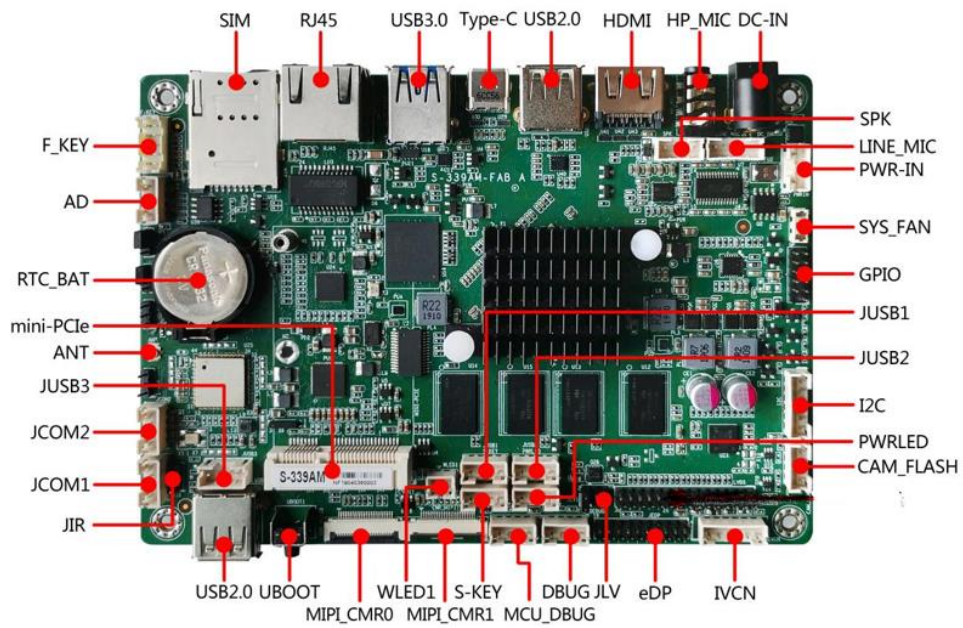

(2) Front IO diagram of the main board



(3) IO diagram behind the main board

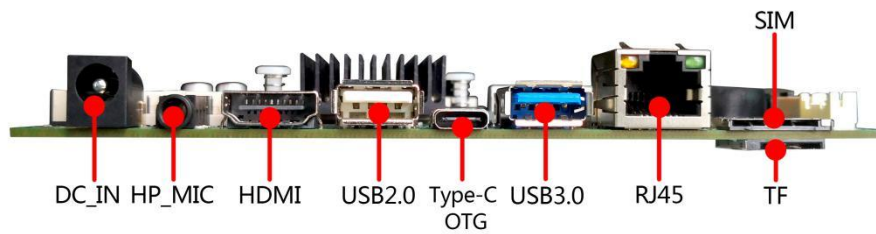

(4) Back view of main board

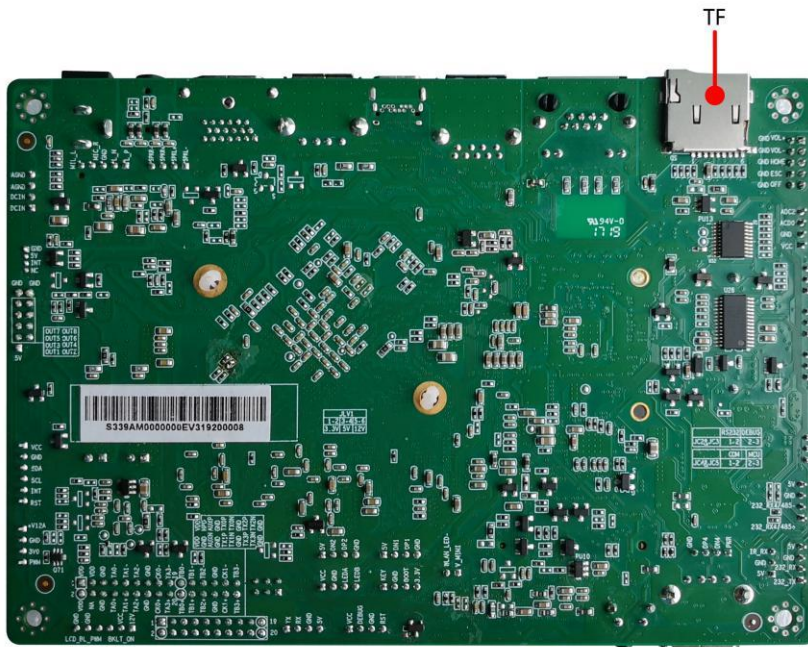

Caution: The identification method of the first pin on the main board is: 1 has a white and bold silkscreen; 2 the pins seen on the back of the main board are square holes.

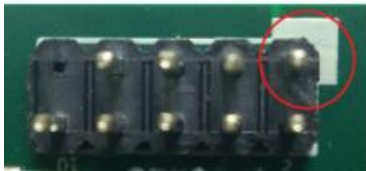

3.3.4 Definition of pin function

(1) Pin Interface Distribution



(2) Description of silkscreens

Silkscreen	Description
DC_IN	+12V DC input interface (ϕ 2.5mm base)
PWRIN	PH2.0-4PIN power input terminal
LINE_MIC	PH2.0-5P LINE-OUT&MIC-IN audio extension socket
UBOOT1	Uboot flash mode button[1]
SPK1	4-PIN PH2.0 amplifier speaker pin (5W/8 Ω)
HP_MIC	3.5mm headset socket
HDMI	Standard HDMI HD digital display interface
TYPEC	Standard USB3.0 Type-C interface[2]
USB1	Standard USB3.0 Type-A single layer interface
USB2	Standard USB2.0 Type-A single layer interface
USB3	Standard USB3.0 Type-A single layer interface
RJ45	Gigabit RJ45 network interface
SIM	SIM card slot
SD	TF expanded card slot
JCOM1	PH2.0-4PIN COM1 RS232 mode pin
TTL_DEBUG	PH2.0-4PIN COM1 TTL battery mode pin (DEBUG serial port)
JCOM2	4PIN-PH2.0 RS232/485 serial port 2 sockets
DEBUG	PH2.0-4PIN onboard MCU module debugging interface
JC2	COM1 RS232/TTL mode setting jumper [3]
JC3	COM1 RS232/TTL mode setting jumper [3]
JC4	COM2 internal onboard MCU/external JCOM2 setting jumper [4]
JC5	COM2 internal onboard MCU/external JCOM2 setting jumper [4]
JIR	DuPont 2.0-3pin infrared receiver extension pin
ANT	WIFI/Bluetooth IPEX antenna interface
BAT	RTC clock 3.3V battery plug
CAM_FLASH	Camera flashlight interface
F-KEY	Function key pin [5]
MINI-PCIE	Mini-PCle module slot
CMR_MIPI0	MIPI-CSI2 camera interface 1
CMR_MIPI1	MIPI-CSI2 camera interface 2
WLLED1	mini-PCle expansion module signal light
JUSB1	4PIN-PH2.0 USB2.0 extension pin 1
JUSB2	4PIN-PH2.0 USB2.0 extension pin 2
JUSB3	4PIN-PH2.0 USB2.0 extension pin 3(and USB1 Co-lay)
S-KEY	4PIN-PH2.0 system power on/off, reset pin
PWRLED	Power indicator pin [6]
JEDP	eDP HD digital display interface [7]
AD	2 way A/D conversion pin
I2C	I2C pin

GP	10PIN-5.08mm 8 reserved programmable control input and output plug-in terminals
SYS_FAN	System cooling fan power supply pin

Remark:

[1] After the main board is powered on, press and hold the Uboot button to enter Uboot mode to upgrade the system;

[2] Type-C interface only supports Slave mode, connect to computer for firmware upgrade;

[3] JC2 and JC3 jointly determine the COM1 signal connection:

Mode	RS232 (JCOM3 pin)	TTL (TTL_DEBUG pin)
JC2&JC3	1-2P short interface	2-3 short interface

[4] JC4 and JC5 jointly determine the COM2 signal connection:

Mode	RS232 (JCOM2 pin)	MCU (485A base)
JC4&JC5	1-2P short interface	2-3 short interface

[5] The extension pin contains function key signals such as volume up, volume down, home, back, and OEM customization;

[6] Preset power indicates two-color lamp extension pin;

(3) Definition of Interface pin and jumper selection

JP/CN	pin#	Signal	pin#	Signal	Remark
LINE_MIC	1	MIC_IN+			
	2	MIC_IN-			
	3	GND			
	4	LINEOUT_R			
	5	LINEOUT_L			
JP/CN	pin#	Signal	pin#	Signal	Remark
SPK	1	SPK_L-			
	2	SPK_L+			
	3	SPK_R-			
	4	SPK_R+			
JP/CN	pin#	Signal	pin#	Signal	Remark
PWR_IN	1	12V			
	2	12V			
	3	GND			
	4	GND			
JP/CN	pin#	Signal	pin#	Signal	Remark
SYS_FAN	1	GND			
	2	+5V			
	3	FAN_INT			
	4	NC			
JP/CN	pin#	Signal	pin#	Signal	Remark

JIR	1	+5V			
	2	GND			
	3	IR			
JP/CN	pin#	Signal	pin#	Signal	Remark
S-KEY	1	PWR_ON			
	2	GND			
	3	RSET			
	4	GND			
JP/CN	pin#	Signal	pin#	Signal	Remark
F-KEY	1	VOL+	2	GND	co-lay 1st PIN and upgrade button co-lay
	3	VOL-	4	GND	
	5	HOME_KEY	6	GND	
	7	BACK_KEY	8	GND	
	9	OEM_KEY	10	GND	
JP/CN	pin#	Signal	pin#	Signal	Remark
PWRLED	1	+3.3V			
	2	GND			
	3	LED_A			
	4	LED_B			

Main board and jumper definition (continued 1)

JP/CN	pin#	Signal	pin#	Signal	Remark
JCOM1	1	RS232_TX			
	2	RS232_RX			
	3	GND			
	4	+5V			
JP/CN	pin#	Signal	pin#	Signal	Remark
JCOM2	1	RS232_TX/485+			
	2	RS232_RX/485-			
	3	GND			
	4	+5V			
JP/CN	pin#	Signal	pin#	Signal	Remark
GP	1	5V (NC)	2		
	3	GPIO1	4	GPIO2	
	5	GPIO3	6	GPIO4	
	7	GPIO5	8	GPIO6	
	9	GPIO7	10	GPIO8	
	11	GND	12	GND	
JP/CN	pin#	Signal	pin#	Signal	Remark
I2C	1	+3.3V			
	2	GND			
	3	TP_SDA			
	4	TP_SCL			
	5	TP_INT			
	6	TP_RSET			
JP/CN	pin#	Signal	pin#	Signal	Remark
JUSB1	1	+5V			
JUSB2	2	DT-			
JUSB3	3	DT+			

	4	GND			
--	---	-----	--	--	--

Main board and jumper definition (continued 2)

JP/CN	pin#	Signal	pin#	Signal	Remark
IVCN	1	+12V			
	2	+12V			
	3	BKLT_ON			
	4	BKLT_PWM			
	5	GND			
	6	GND			
JP/CN	pin#	Signal	pin#	Signal	Remark
JP/CN	pin#	Signal	pin#	Signal	Remark
JP/CN	pin#	Signal	pin#	Signal	Remark
JEDP	1	VCC	2	VCC	
	3	HPD	4	GND	
	5	EDP_AUX+	6	EDP_AUX-	
	7	GND	8	GND	
	9	EDP_TX0+	10	EDP_TX1+	
	11	EDP_TX0-	12	EDP_TX1-	
	13	GND	14	GND	
	15	EDP_TX2+	16	EDP_TX3+	
	17	EDP_TX2-	18	EDP_TX3-	
	19	GND	20	GND	

Main board and jumper definition (continued 3)

JP/CN	pin#	Signal	pin#	Signal	Remark
AD	1	+3.3V			
	2	GND			
	3	AD1			
	4	AD2			
JP/CN	pin#	Signal	pin#	Signal	Remark
WLED	1	+3.3V			
	2	WLAN_LED-			
JP/CN	pin#	Signal	pin#	Signal	Remark
CAM_FLASH	1	+12V			
	2	GND			
	3	Flash_ON			
	4	FLASH_PWM			
JP/CN	pin#	Signal	pin#	Signal	Remark
CMR_MIPI0 CMR_MIPI1	1	AGND			
	2	+2.8V			
	3	+1.8V			
	4	+1.5V			
	5	GND			
	6	CMR_CLK			
	7	GND			
	8	MIPI_RX_CLK+			

9	MIPI_RX_CLK-		
10	GND		
11	MIPI_RX_D2+		
12	MIPI_RX_D2-		
13	+2.8V		
14	MIPI_RST0		
15	CIF_PDN1		
16	I2C_SDA_CAM		
17	I2C_SCL_CAM		
18	GND		
19	MIPI_RX_D3+		
20	MIPI_RX_D3-		
21	MIPI_RX_D0+		
22	MIPI_RX_D0-		
23	MIPI_RX_1+		
24	MIPI_RX_D1-		

4. Reference of Structure Design

4.1 Installing Interface of Host Computer

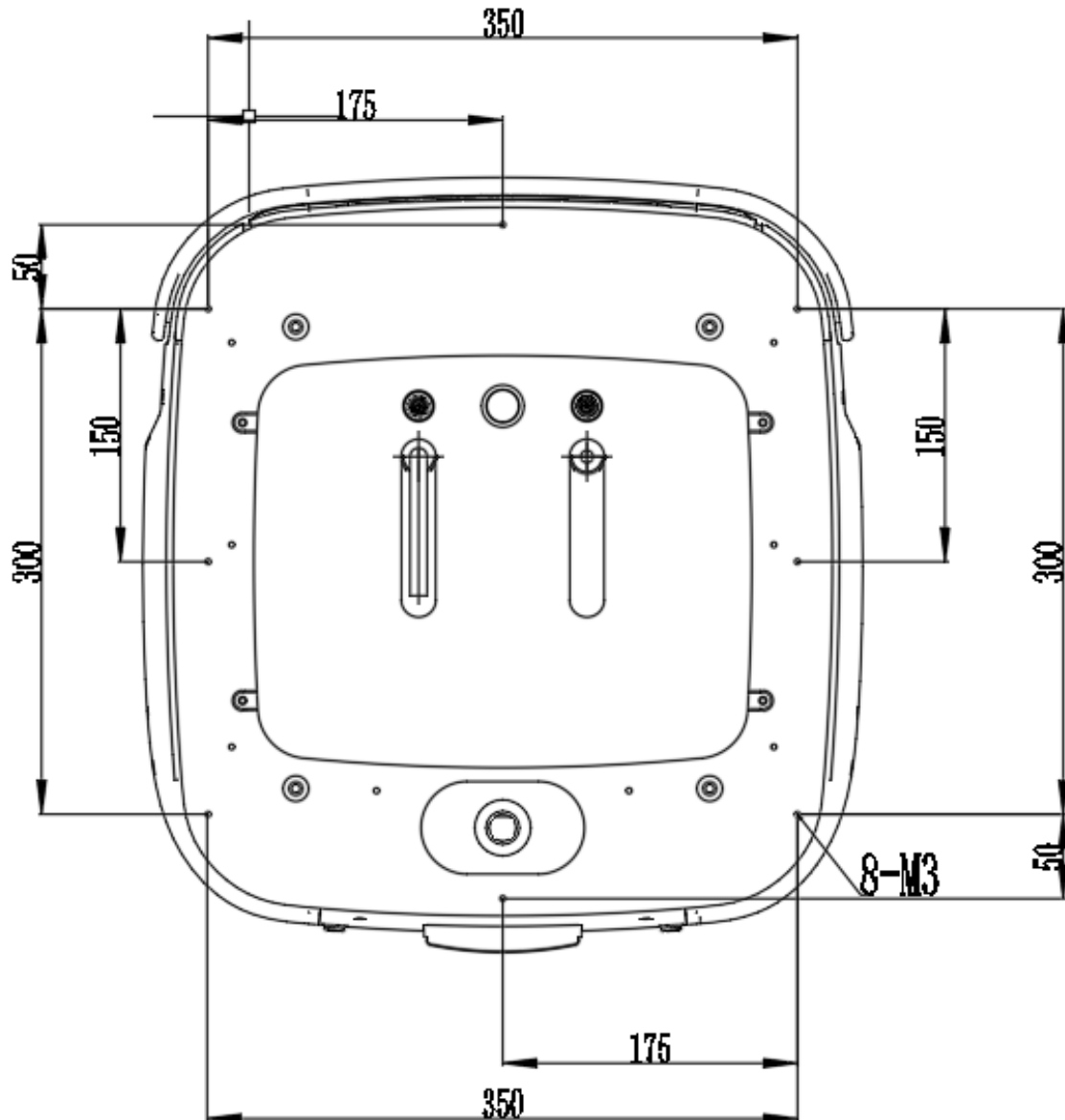

As shown in the figure above, there are a total of 8 M3 threaded holes for the installation and fixation of the host computer.

It is recommended to use M3 screws with spring washer and blue anti-loosening glue.

4.2 Instruction of Load Limit

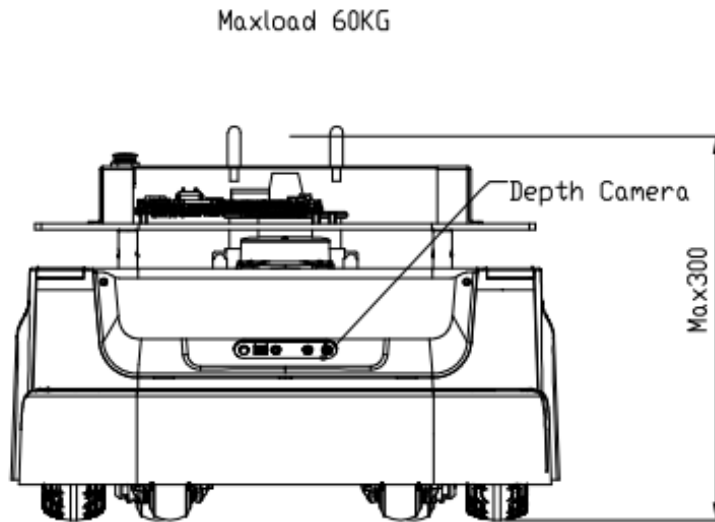

(1) Max load of host computer is 60 kg, Rated load is about 40kg..

(2) * It is recommended that the center of gravity of the whole machine is not higher than 300mm from the ground during installation.

- i. *The center of gravity of chassis is the one which Slamtec provides, the height is 82 mm;
- ii. The center of gravity of the whole machine is the overall center of gravity of the chassis plus the robot;
- iii. If the center of gravity of the whole machine exceeds 300mm, the slope-climbing and obstacle-crossing performance may be reduced.

4.3 Radar Clearance Area

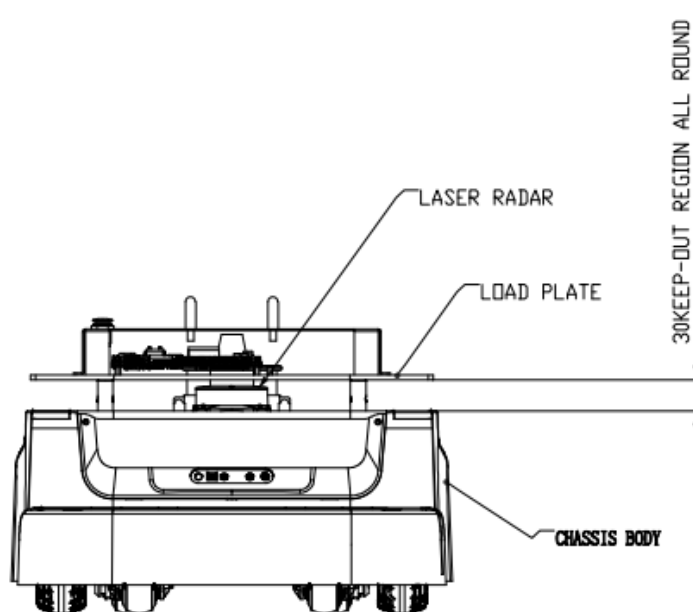

There is a radar between the chassis body and the host computer, which requires a certain clearance area to avoid being shielded or interfered;

The boundary of the host computer cannot exceed the lower boundary line of the host computer as shown in the figure.

4.4 Deep Camera Clearance Area

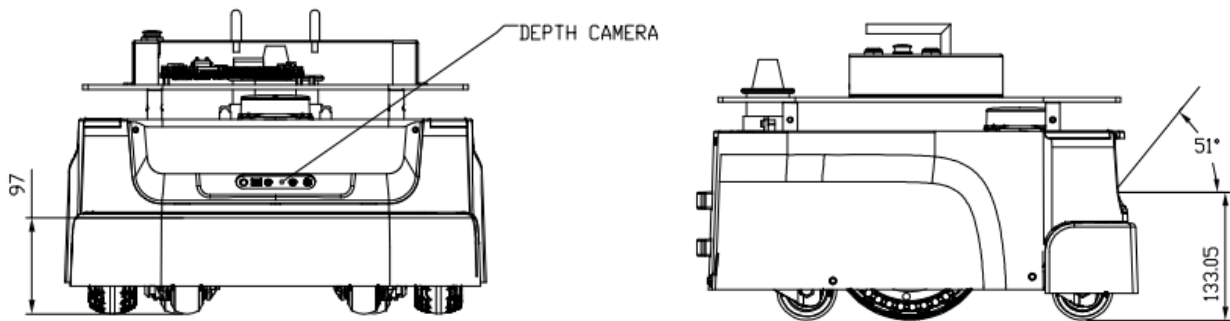

There is a deep camera on the chassis, which requires a certain clearance area to avoid being shielded or interfered;

The host computer cannot exceed the clearance area as shown in the figure. Due to the angled layout of the dual cameras, the superimposed clearance area is larger than a single FOV.

5. Setup Instructions

5.1 Opening

1. After receiving the Athena2.0 machine, please check whether the packing box is intact as shown in the left picture, and whether the box on the right side of the Athena2.0 sample of the outer box is checked. After confirming that the packing is complete and the box contains Athena2.0, use packing pliers to cut the packing tape, remove all packing straps and paper corners, it should be shown as on the right picture.

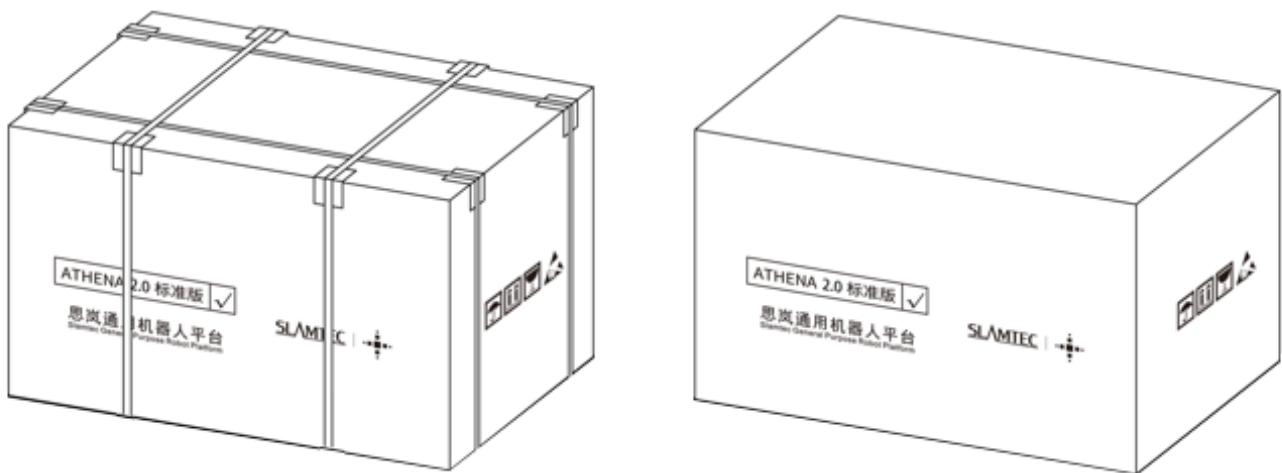

5-1 Athena2.0 unpacking

5.2 Placing Charging Base

Athena2.0 can be charged by returning to the charging base automatically, so the position of the charging base will affect the automatic return charging function of Athena2.0. When Athena2.0 returns to the charging station, it will generate propelling force. Therefore, it is best to place the charging stand with its back against the wall. The wall must meet the following conditions:

- a. The charging base must be attached to the wall, without no obstacle in the middle, try to avoid the wall with skirting, etc.
- b. The wall material cannot be high-permeability materials, such as mirror or glass
- c. The wall width needs to be at least three times wider than the width of the charging stand
- d. The wall must be a straight wall, not a curved wall

The charging base needs to be connected to a 220V power supply. The length of the external power cord of the charging base is 1.5m. Therefore, it is necessary to ensure that there is a 220 V interface within 1.5m of the wall against which the charging base rests. The ground wiring harness is messy causing unnecessary trouble).

The ground in front of the charging base must meet the following conditions:

- a. Open, with no obstacles within a radius of 2m in front of the charging stand as the center of the circle
- b. Plane, no slope
- c. The ground cannot be covered with soft carpet that causes Athena2.0 to sink more than 2cm

To ensure that Athena2.0 automatically returns to the charging function, it is necessary to ensure that Athena2.0 always starts from the charging base.

Note: If you want to change the position of the charging stand, you need to set the corresponding setting according to the position you need when loading the map. For detailed operations, please see the SDK corresponding interface operation document.

5.3 Power ON/OFF

Power on: if the machine is not in the position of charging pile, long press the power switch until the power switch indicator lights up and release it. The machine system enters the startup process, the front light strip lights up, and the wheel hub is in the brake state, indicating that the startup is completed.

If the machine is in the position of charging pile, short press the power switch until the power switch indicator lights up and then release it. The machine system enters the startup process, the front light strip lights up, and the wheel hub is in the brake state, indicating that the startup is completed.

Power off: long press the power switch until indicator light goes out, then release it, the machine enters the shutdown process, the light strip on the front of the machine goes out, and the machine can be pushed arbitrarily, indicating that the shutdown is completed.

5.4 Charging

As shown in the figure below, align the charging piece of the machine with the charging electrode of the charging pile. After waiting for 10 seconds, the front light strip of the robot lights up, the wheel hub enters the braking state, and the breathing light of the charging pile flashes, indicating that charging has started.

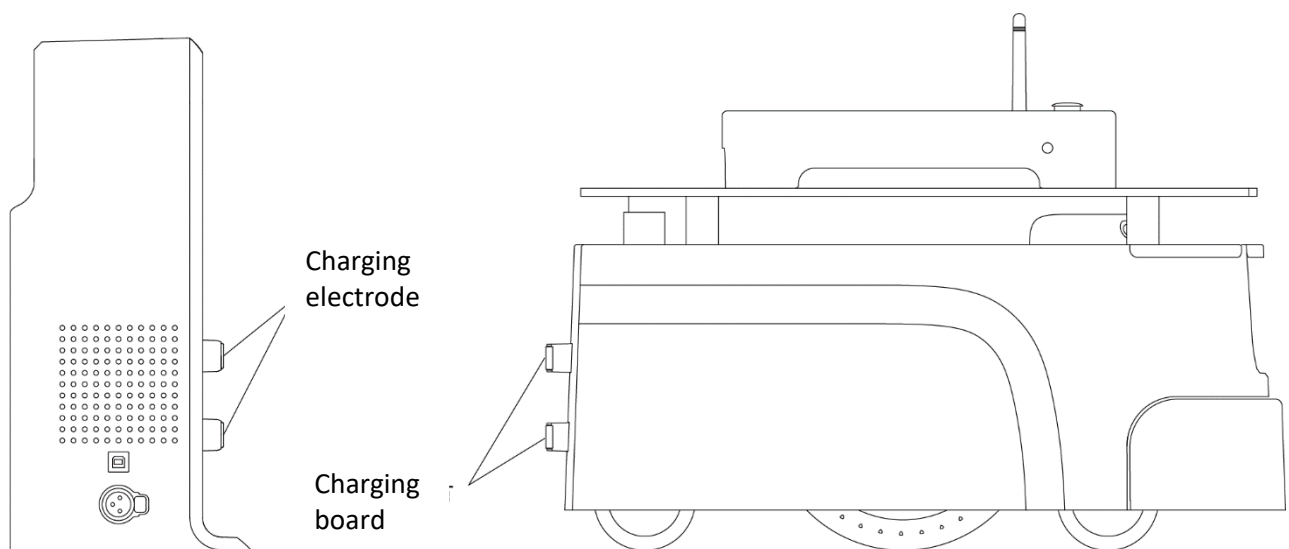

5-2 Athena2.0 charging

5.5 Emergency stop & brake and reset

(1) Emergency stop button

Press the emergency stop button, the Athena2.0 machine will stop immediately, stop and no longer respond to any motion control commands, and the manual push is blocked.

Release the "emergency stop button " and the machine can return to normal working conditions.

(2) Brake button

Press the "brake button", the Athena2.0 machine will stop immediately, stop and no longer respond to any motion control commands. The machine can be pushed manually, such as pushing it to the charging pile.

Release the "brake button", the machine can return to normal working condition, and the manual push is blocked.

5.6. Connection to Computer

【Step 1】 The hotspot of the computer connected to the chassis

Athena 2.0's hotspot is auto-started by default, the hotspot format is: SLAMWARE-XXXXXX

Hot spot identification method: query the last six digits of the SSID in the chassis label.



5-3 Chassis label SSID

For example, if the label SSID: Robot-D70CED, the hot spot of this Chassis is SLAMWARE-D70CED

【Step 2】 Download and install Slamtec RoboStudio from the official website of Silan



5-4 Official Slamtec RoboStudio

If you downloaded slamtec robostudio, After logging in to RS, click the "Robot" option and manually connect the robot with the right mouse button.

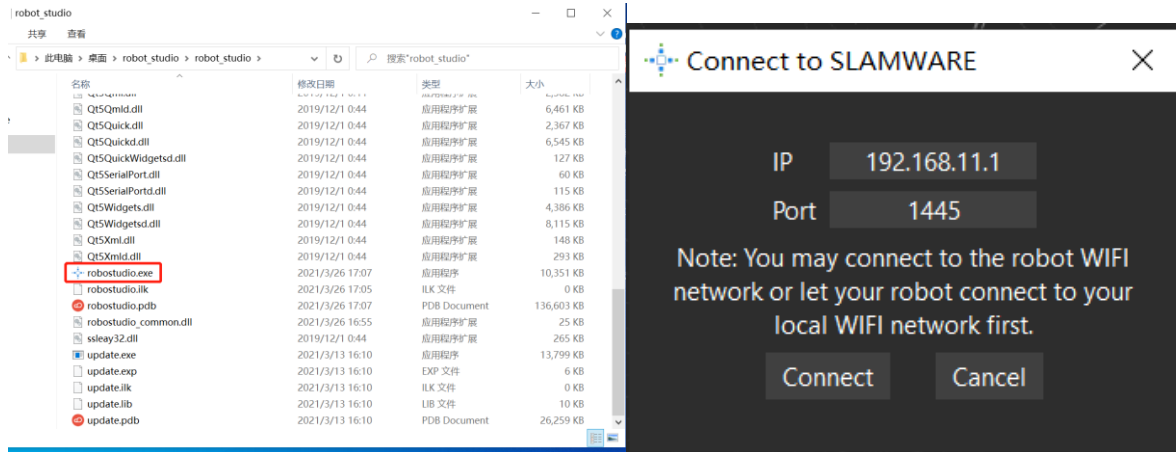

5-5 Robo studio login screen

[step 3] if you downloaded slamtec robostudio, run "robostudio.exe", enter the interface of slamtec robostudio, enter the IP address and port, click "connect", and RS login succeeds.

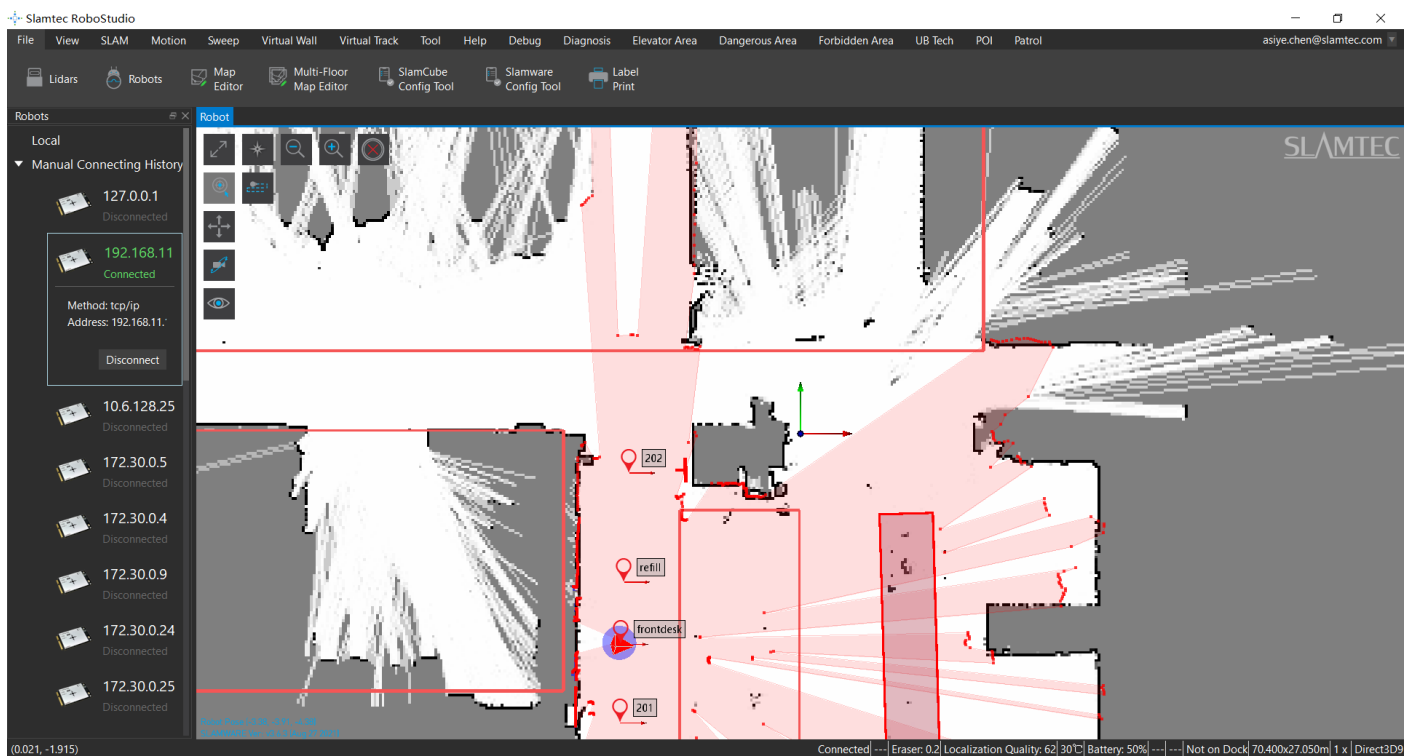

5-6 Robo studio interface

Note : The method of IP address query is to press the shortcut key, Windows+R, and enter the code ipconfig. Copy the IP of the default gateway and paste it into the IP address box of Slamtec RoboStudio. Click Connect to enter Slamtec RoboStudio.

```

C:\WINDOWS\system32\cmd.exe
Microsoft Windows [版本 10.0.18363.1734]
(c) 2019 Microsoft Corporation。保留所有权利。

C:\Users\ena.liu>ipconfig

Windows IP 配置

无线局域网适配器 本地连接* 1:

    媒体状态 . . . . . : 媒体已断开连接
    连接特定的 DNS 后缀 . . . . . :

无线局域网适配器 本地连接* 2:

    媒体状态 . . . . . : 媒体已断开连接
    连接特定的 DNS 后缀 . . . . . :

无线局域网适配器 WLAN:

    连接特定的 DNS 后缀 . . . . . :
    本地链接 IPv6 地址. . . . . : fe80::78a1:69ee:c308%7
    IPv4 地址 . . . . . : 192.168.11.243
    子网掩码 . . . . . : 255.255.255.0
    默认网关. . . . . : 192.168.11.1

以太网适配器 蓝牙网络连接:

    媒体状态 . . . . . : 媒体已断开连接
    连接特定的 DNS 后缀 . . . . . :

C:\Users\ena.liu>

```

5-7 Method of obtaining an IP address

5.7 Map Building and Upload

Download and install the robot graphical control management tool Robot Studio from our official website <http://www.slamtec.com/cn/RoboStudio> to adjust and use Athena2.0, sign up account and log in. In the menu-toolbar area, click "File-Robot" in turn, and a docking page named Robot will appear on the left side of the workspace, as shown in the figure below. The user connects/disconnects the robot through this page.

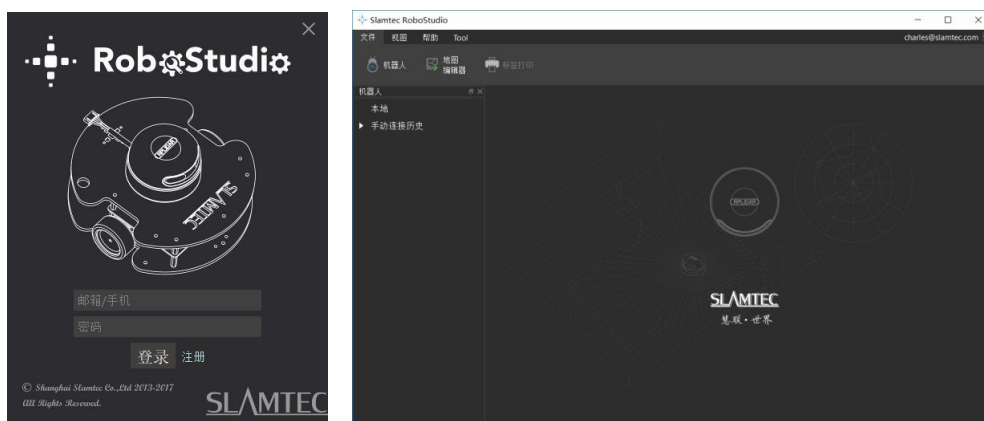

5-8 Rob Studio Robot page

Right-click the blank space of the robot list, click "Manually connect robots" in the pop-up menu, and the connect robot dialog box will pop up (as shown below). Enter the IP address and port number of the

Athena2.0 robot above and click the connect button to connect (This connection method is suitable for machines that have been assigned an IP address through the Web portal management backstage). When the computer has been connected to the SSID of the aforementioned Athena2.0 robot through a network adapter (SSID can be viewed on the label of the machine), enter the IP address 192.168.11.1 by default (note that your wireless network adapter IP address should be set to automatically obtain it using DHCP).

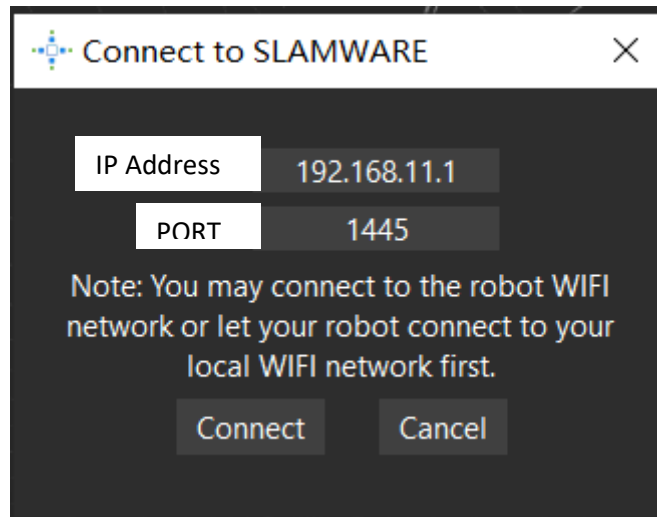

5-9 Rob Studio Robot connecting page

When finishing connecting, the work area will display the robot, map information, and status information. In the robot page, you will find that the name of the connected device turns green, and the status is "Connected", as shown in the figure below.

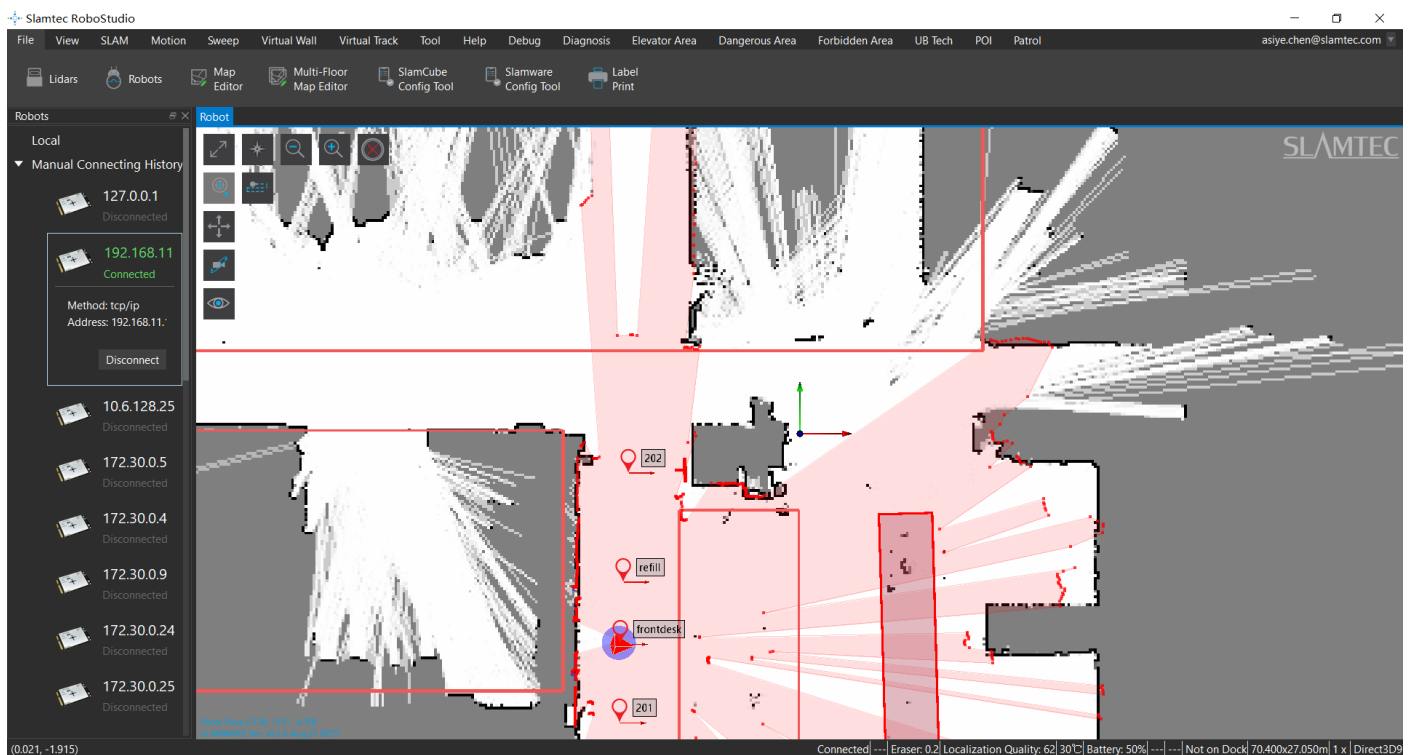

5-10 Rob Studio Robot connecting page

Left click the spot inside the map-building area, let Athena2.0 build the map. When finishing, please use the virtual wall function to isolate the places that need to be isolated. Then click "File-Map Editor" in turn, choose to save the file or upload to the firmware to save the map.

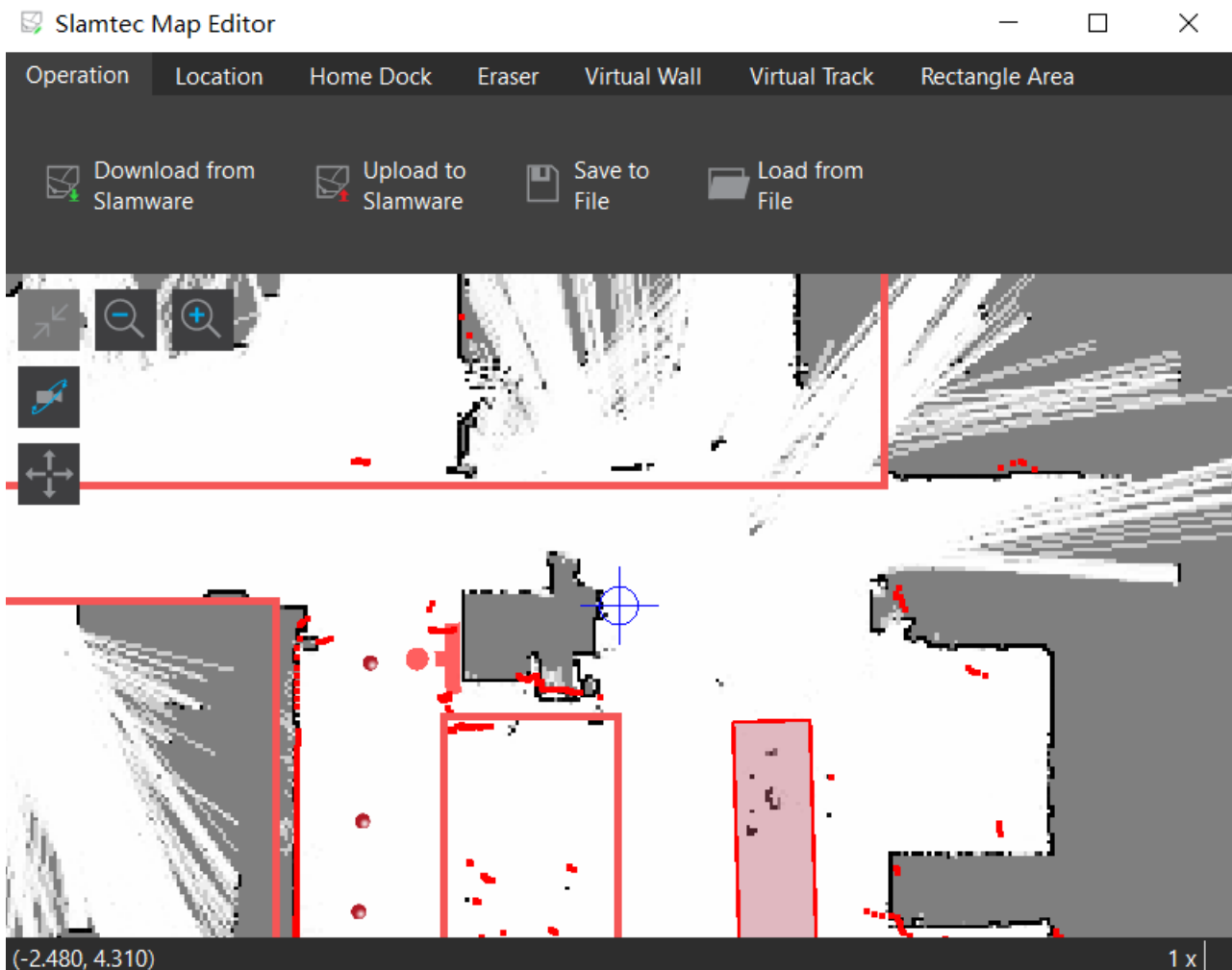

5-11 RoboStudio Robot Map Editor Window

There is a difference between the functions of restricted areas and virtual walls.

Restricted Area: When the Athena 2.0 is accidentally pushed into the restricted area, the Athena 2.0 machine can be automatically freed from the restricted area by giving a random point in RoboStudio.

Virtual Wall: When a human accidentally pushes Athena 2.0 into the virtual wall, the Athena 2.0 machine cannot automatically get out of the virtual wall and needs to be pushed out by a human at a random point in RoboStudio.

The Forbidden Area management function relies on the Slamware Forbidden Area plug-in. Slamware Forbidden Area is a public plug-in, the computer is connected to the Internet, after logging in RoboStudio, click Tools -> Plug-ins -> Shop -> All -> Slamware Forbidden Area -> Get -> Download -> Restart RoboStudio.

Public plug-in links:

<https://wiki.slamtec.com/pages/viewpage.action?pageId=56164379>)

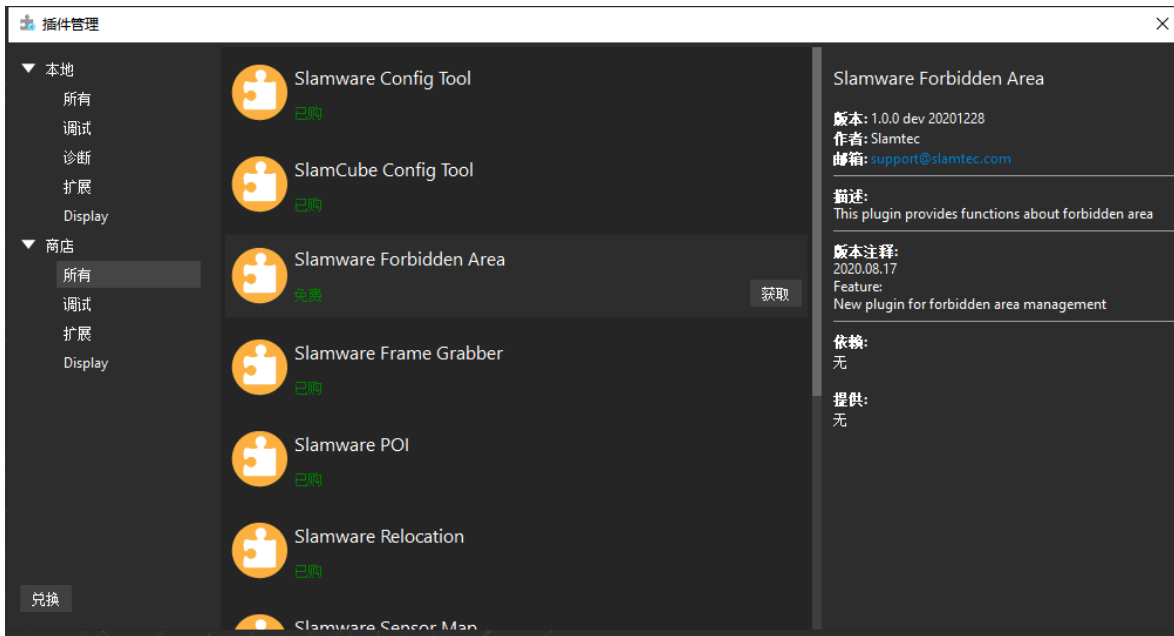

5-12 RoboStudio Public plug-in

After the plug-in runs normally, connect to the machine, you can see the "Ban zone" toolbar in the menu bar.



5-13 RoboStudio No-go areas

5.8 Host Computer Completes Startup and Loading The Map

Below is a reference example of how to use the SDK to complete the startup and loading of a specific map on the host computer.

```

1.  /*
2.  * upload map file
to Athena2.0 3.  */
4.  #include <iostream>
5.  #include <rpos\robot_platforms\slamware_core_platform.h>
6.  #include <rpos\robot_platforms\objects\composite_map_reader.h>
7.  #include <rpos\core\pose.h>
8.
9.  using namespace std;
10.
11. int main()
12. {
13.     try
14.     {
15.         string map_path = ".\\map.stcm"; //the path of map
16.         string Athena2.0_ip = "192.168.11.1"; //the ip of Athena2.0
17.         int Athena2.0_port = 1445; //the port of Athena2.0 ,default is 1445
18.
19.         rpos::robot_platforms::SlamwareCorePlatform Athena2.0 =
20.             rpos::robot_platforms::SlamwareCorePlatform::connect(Athena2.0_ip, Athena2.0_port);
21.         //connect to the Athena2.0

```

```
22.     rpos::robot_platforms::objects::CompositeMapReader cmapreader;
23.     //map reader
24.     rpos::core::Pose Athena2.0_pose = rpos::core::Pose(rpos::core::Location(0, 0, 0));
25.     //the Athena2.0 pose in map(Athena2.0_pose should be the Athena2.0's real pose in new map)
26.     //using Athena2.0.getpose() to get the old Athena2.0 pose
27.     auto map = cmapreader.loadFile(map_path);
28.     //load map
29.     Athena2.0.setCompositeMap(*map, Athena2.0_pose);
30.     //set compositemap
31.     rpos::core::Pose home_pose = rpos::core::Pose(rpos::core::Location(0, 0, 0));
32.     //the home pose in map(home_pose should be the home's real pose in new map)
33.     //using Athena2.0.gethomepose() to get the old home pose
34.     Athena2.0.setHomePose(home_pose);
35.     //set home pose
36. }
37. catch (rpos::robot_platforms::ConnectionFailException &e)
38. {
39.     cout << "connect failed on " << e.what() << endl;
40. }
41. catch (rpos::system::detail::ExceptionBase &e)
42. {
43.     cout << "failed on " << e.what() << endl;
44. }
45.
46. return 0;
47. }
```

Further motion deployment details, please see the SDK instruction document

6. Adjusting Tools

6.1 RoboStudio

RoboStudio graphical tools are used to adjust and use Athena2.0, please download and install it from our official website: <http://www.slamtec.com/cn/RoboStudio>, and coming with manual to introduce those features.

6.2 Web Management Backstage

In the process of developing, adjusting and using SLAMWARE equipment, various operations can be performed on the equipment through the web management backstage, such as viewing basic information, updating the version, configuring WiFi, etc. (Default username: admin, default password: admin111)

Currently, web management backstage supports following functions:

1. Check basic information of the device
2. Restart the module
3. Update the firmware

Slamtec will regularly provide Athena2.0 firmware updates and upgrades. You can easily upgrade the firmware for Athena2.0 through the management backstage. Please obtain the latest firmware from sales or technical support personnel. The update process will last 5-10 minutes. The buzzer of Athena2.0 will continue to sound during the update, and Athena2.0 will automatically restart after the update. Before that, please make sure that Athena2.0 has sufficient power.

4. Configuring WIFI
5. Start the SLAMWARE Core diagnostic mode
6. Modify the administrator password

More details on usages please refer to:

<https://wiki.slamtec.com/display/SD/SQ001+SLAMWARE+Web+Portal+Function+Overview>

7. Developer Tools

7.1 Start Using

The Agent SDK of the Athena2.0 chassis is developed based on the C++ language to reduce user access costs and improve the robustness of the SDK. At the same time, it has strong compatibility and supports multiple languages such as Java, C++, C, and Kotlin. The following is a detailed introduction to the relevant examples and usage guidelines of the Agent SDK call based on the Athena2.0 chassis.

7.2 Inter-system Adjusting Framework

Robot App controls the robot's positioning, movement, and return to piles through communication; at the same time, Robot App sends instructions to the robot according to various business scenarios, and Robot Agent will provide data interfaces, task operation interfaces, and business services to Robot App.

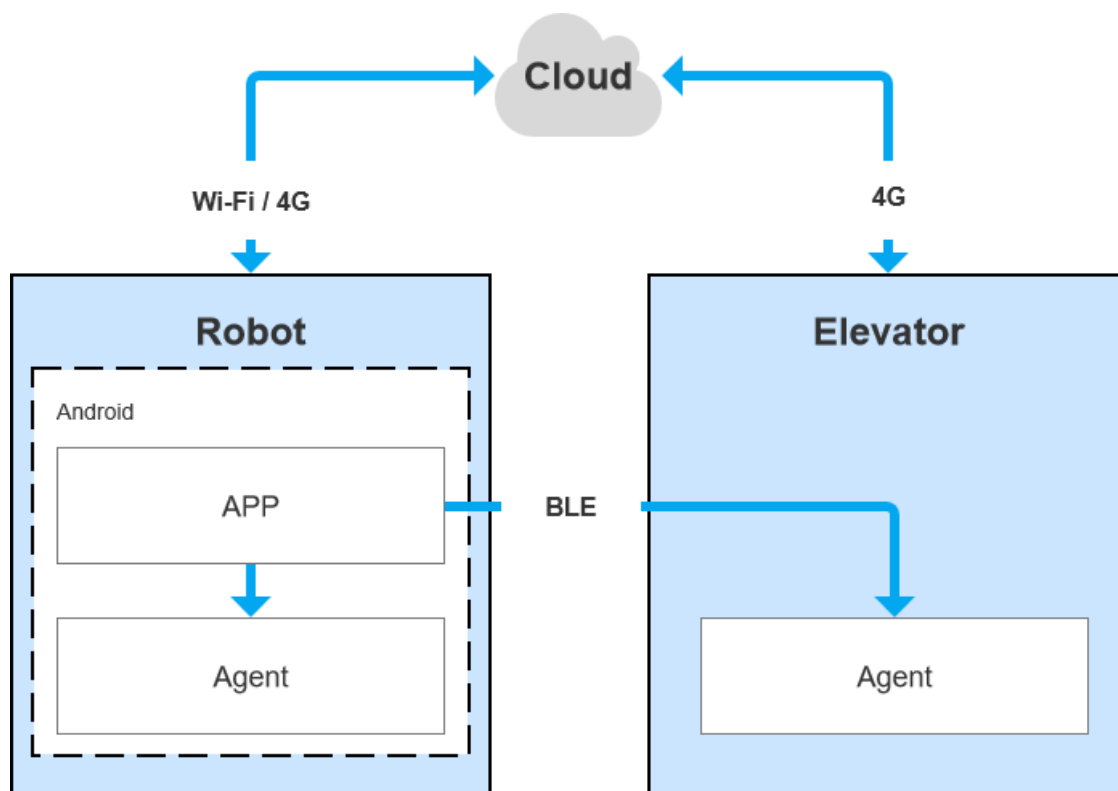

7-1 COMMUNICATION BETWEEN EACH SYSTEM OF ATHENA2.0

7.3 Instructions of Each System

7.3.1 Robot Agent

Robot Agent is a service program running on the Athena2.0 chassis, through which the cloud and the elevator control terminal communicate with the elevator control equipment. Inside the Robot system, the Robot Agent communicates with the Robot App, receives instructions from the Robot App to control the Robot, and sends the Robot status at the same time.

The core function of Robot Agent is:

- ✓ Communicate with the Robot Cloud, Robot APP, send the Robot status and receive instructions

7.3.2 Elevator Agent

Elevator Agent is a service program running on the Linux system of the elevator control main control box. The cloud and the robot end communicate with the elevator control equipment through it. Inside the elevator control system, the Elevator Agent communicates with the Elevator Controller through UDP, sending elevator control instructions and obtaining elevator status.

The core function of Elevator Agent is:

- ✓ Communicate with the Robot Cloud, Robot APP, send the elevator status and receive instructions of elevator control
- ✓ Communicate with the Elevator Controller, receive the elevator status and send instructions of elevator control

7.3.3 Robot Cloud

Robot Cloud is a set of services provided to realize remote management, scheduling, and control of robots. It runs in the cloud and communicates with the robot at one end and the elevator control equipment at the other end. Therefore, elevator control is part of the function. Robot Cloud communicates with the Elevator Agent running on the main control box of the elevator control through the MQTT protocol.

Its core functions include:

- ✓ Send instructions, control the elevator to the designated floor
- ✓ Send instructions, control the elevator to open the door
- ✓ Send instructions, control the elevator to close the door
- ✓ Receive the up/down status of elevator
- ✓ Receive the current floor of the elevator

7.3.4 Robot App

Open-Source application – Restaurant Delivery App

The restaurant delivery app is a service program running on the robot. The application scene is a restaurant. It draws a map and loads it to the robot's local area through RoboStudio graphical tools. It is a universal application for human-computer interaction to achieve multi-point task delivery.

7.4 Demonstrations of Code

1. The following is an example of the Robot APP calling the Robot Agent interface to check the battery status

```
GET http://127.0.0.1:1448/api/core/system/v1/power/status
```

The format of the returned data is application/json

```

interface AgentApi {
    /**
     * get方式调用 value: 接口地址
     * PowerStatus: 接口返回json格式对应的bean格式的数据 class的值
     */
    @GET("/core/system/v1/power/status")
    fun queryPowerStatus(): Call<PowerStatus>
}

/**
 * batteryPercentage : 90电池电量百分比, 0 ~ 100
 * dockingStatus : 对桩状态
 * isCharging : 是否正在充电...
 */
data class PowerStatus(
    val batteryPercentage: Int, val dockingStatus: String, val isCharging: Boolean,
    val isDCConnected: Boolean, val powerStage: String, val sleepMode: String
)

/**
 * retrofit接口代理类
 */
object AgentServiceCreator {
    fun <T> create(serviceClass: Class<T>, timeout: Long): T =
        Retrofit.Builder().baseUrl("http://127.0.0.1:1448/api/")
            .addConverterFactory(GsonConverterFactory.create()).client(
                OkHttpClient.Builder().retryOnConnectionFailure(true)
                    .connectTimeout(timeout, TimeUnit.SECONDS)
                    .addInterceptor { chain ->
                        val originalRequest = chain.request()
                        val requestBuilder =
                            originalRequest.newBuilder().addHeader("Connection", "close")
                        chain.proceed(requestBuilder.build())
                    }.build()
            ).build().create(serviceClass)
}

// 查询电量, 返回值为powerstatus
val powerStatus = AgentServiceCreator.create(AgentApi::class.java, 1L).queryPowerStatus().await()
    Result.success(powerStatus)

```

2. The following is the Robot App calling the Robot Agent interface to make the robot move across floors

POST http://127.0.0.1:1448/api/core/motion/v1/actions

The request message format is application/json

```

{
  "action_name": "slamtec.agent.actions.MultiFloorMoveAction",
  "options": {
    "target": {
      "poi_name": "201" //表示前往名称为 201的poi
    }
  }
} // JavaScript Document

```

7.5 Details Of Robot API

FUNCTION OF MODULES	API LIST
Locate, map building-related functions	Get the Robot location
	Set the Robot location
	Get quality of location
	Whether support locating
	Start/Close locating
	Whether start map building
	Start/ pause map building
	Get location of power station
	Set location of power station
	Get current map
	Delete current map
Mark map elements manually	Get all virtual line segment
	Add virtual line segment
	Adjust virtual line segment
	Delete virtual line segment
	Delete virtual line segment
	Get all POI in current map
	Add POI
	Empty POI
	Find POI according to ID
	Modify POI
	Delete POI
Motion control of the Robot	Get all supported actions
	Get current action
	Stop current action
	Create new action
	Check action status
Firmware Upgrade	Get firmware upgrade process
Android application management	Get all custom installed apps
	Install APP
	Uninstall an APP
Multi-floor map and POI management, taking elevator, etc.	Move across floors
	Go back across floors
	Get all floor info
	Get floor info of floor of the robot
	Setup info of floor of the robot
	Get POI info
	Upload map to the robot
	Long-lasting save the map
Reload the map	
Delivery service-related interfaces	Get password of the action

	Set password of the action
	Get configuration info of the device
	Get setup info related to the delivery
	Check task info
	Create task
	Cancel all task
	Cancel some task
	Get current mission status
	Stop/ continue current mission
	Start picking up items
	End picking up items
	Get info of objects
	NOTE: delivery business please inform marketing department
	Restaurant delivery service-related interfaces
Get the health info of the device	
Get POI info	
Get password of the action	
Make up new actions	
Get current action	
Terminate current action	
Shut down or restart the robot	

MORE DETAILS OF API: <https://github.com/slamtec/Athena2.0SampleApp>

8. Introduction And Use Of Elevator Control

8.1 Introduction

Intelligent elevator control, independently developed by Shanghai SLAMTEC CO., Ltd, can provide accurate detection of elevator status, program control call elevators, control elevators, combined with Mercury II hotel robots, helping the robots to take and exit the elevators autonomously. Providing reliable solutions to multi-floor operation scenarios. In addition to working with hotel robots, the product can be used as an independent set of solutions. Through the API interface we provide, this product can also interact with other smart devices or products to meet the different customization needs of customers. At the same time, the product can also be seamlessly connected to the Athena2.0 chassis, to provide technical service support for more specific needs in other scenarios.

8.2 Features

8.2.1 Intelligence Elevator Control

The core function of this product is to help robots and other intelligent devices to control the elevator, such as calling the elevator, going to the designated floor, and controlling the elevator to open and close the door. This function greatly improves the business scenario of robots and breaks the previous limitation that robots can only work on the same floor.

8.2.2 Intelligence Status Detection

Through the built-in sensor and adaptive algorithm, this product can accurately detect the current floor, up and down status of the elevator, real-time to the millisecond level, with an accuracy of more than 96%, providing a very critical foundation so that the robot can enter and exit the elevator correctly and complete the work.

8.2.3 Elevator Diversity Adaption

The main control box has developed a variety of optimized filtering algorithms, so that this product is suitable for many different types of elevators, such as single-door elevators, double-door elevators, front and rear door elevators, etc. As it covers as many scenes as possible, this product can be used in most elevators at present. Users only need to simply calibrate and adjust through the APP provided after installing the equipment.

8.2.4 Multi-Level Network Adaption

Considering the limitations of the elevator network, how to ensure data interconnection and program interoperability is a very critical factor, and relatively it is also a difficult point. After continuous optimization iterations, we finally found a way to solve this problem. This product provides 4G, WIFI, BLE and other multi-level network communication methods to interact with robots and other smart devices to ensure the reliability of the communication link.

8.2.5 OTA Remote Upgrade

Support OTA remote upgrade of software and firmware, and batch deployment. At the same time, it provides support for VPN, which can remotely log in to the Linux system of this product for upgrades and other operations. Through the OTA function, real-time updates, upgrades and optimization can be done.

8.2.6 Interface Support

The intelligent elevator control provides a consistent API interface to the outside world, supports Bluetooth, MQTT, and HTTP communication protocols. Customers can control and interact with the elevator by writing their own program code. At the same time, it supports secondary development to meet the different customization needs of customers.

8.2.7 Swipe To Bypass

For some elevators that require a swipe card to ride, this product can also be easily supported. Just install the equipment we specify when installing the device, and then turn on the swipe card to bypass it in the APP. In this way, even if there is a card reader, it can be easily bypassed and freely enter and exit the elevator.

8.2.8 Unified Management

The cloud platform provided by SLAMTEC can perform real-time monitoring of the status of all deployed products, batch upgrades, and further data mining through online management, information statistics, equipment monitoring, etc., to provide exclusive accurate data models for hotels or commercial buildings, to guide them to improve their overall operational capabilities and service quality.

To know more about the detailed solution of elevator control, obtain it from the marketing department.
[Elevator control user manual->>](#)

Note: This intelligent elevator control can only be used in China. For foreign customers, it needs R & D evaluation and customization.

9. Special Note

9.1 Charge point deployment

Precautions for the selection of charging pile location:

(1) The charging pile should be placed on the wall with a space of more than 0.35 meters on both sides and more than 1 meter in front;

(2) The charging pile shall be close to the wall, and shall not be placed in the mirror wall, back hollowed out and other areas, etc;

(3) The position of the charging pile must not be placed on soft ground such as carpet, otherwise it will cause height difference and cannot be charged;

(4) The position of the charging pile in the scene needs to be marked to prevent incorrect recovery after moving.

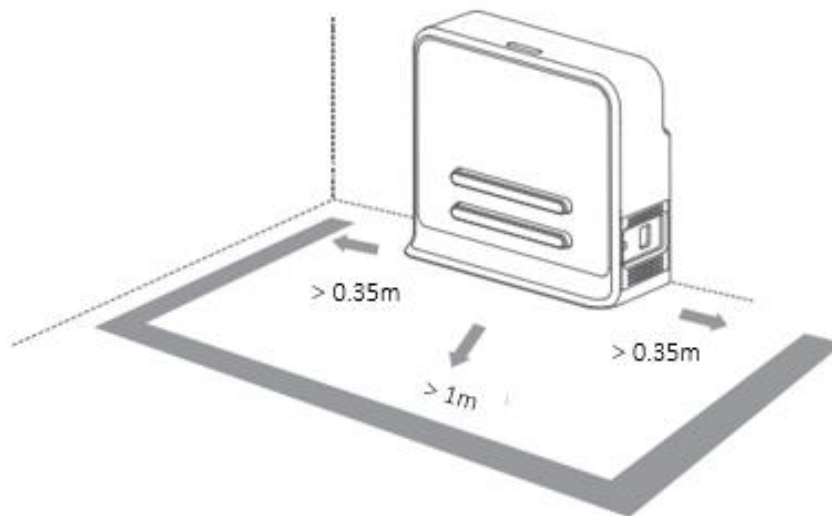

9.2 Restricted usage scenarios

Please avoid using Athena2.0 chassis in the following scenarios to avoid chassis failure or damage.

(1) Overrun/heavy transportation

Do not put in items that exceed the maximum weighing parameter value to avoid affecting the normal use of Athena2.0. Please refer to the information in the product parameter table for the maximum load-bearing parameter value.

(2) Sill height

Please ensure that there are no obstacles more than 20mm in front of Athena2.0, and the maximum height of Athena2.0 over the sill is 20mm. During Athena2.0 driving, please try to avoid passing through uneven ground or other environments with large height.

(3) Man-made impact

Do not forcefully push or hit the Athena2.0 body when Athena2.0 is in normal use.

(4) Temperature / humidity

Do not place Athena2.0 in places with high temperature, high humidity or water stains.

(5) Ground obstacles

Please ensure that the ground is clean and free of wireless obstacles and sundries.

(6) Outdoor

Do not use the machine outdoors.

(7) It is limited to safe use below 2000m above sea level.

9.3 Faults that cannot be handled temporarily

When the machine encounters a fault that cannot be handled temporarily, you can try the following operations:

(1) Please press the brake button;

(2) Push the machine back to the charging pile;

(3) The machine can be forced to switch on and off in any state after power-on.

*Use only in emergency situations.

9.4 Notes

Notes for storage:

(1) Since the machine contains battery, it should be stored in a cool and dry environment;

(2) For long-term storage (more than 3 months), it is recommended to put it in a dry environment with room temperature of 10-25 °C and no corrosive gas;

(3) Athena2.0 shall be charged every 6 months during long-term storage to ensure that the voltage of each battery unit is in the range of 3.6v-3.9v.

Packing notes:

(1) The packaging material must have a certain degree of strength and toughness, and can withstand slight vibration, extrusion, friction and collision during transportation;

(2) There should be padding around the package, which can play a good cushioning role;

Notes for transportation, loading and unloading:

(1) Please handle with care to prevent falling, collision, dragging and inversion;

(2) Stacking needs to be built firmly, compactly, stably and neatly;

Other notes:

(1) Do not treat Athena2.0 violently (such as kicking, pushing, pulling);

(2) Do not spill liquid on the machine;

- (3) Do not use the automatic recharge function on the soft carpet with a subsidence of more than 2cm;
- (4) It is recommended to start the equipment on the charging base;
- (5) Do not change the inside of the machine without authorization;
- (6) In environments with many high-transmittance materials, please use auxiliary protection functions, such as virtual walls.

10. Maintenance

1. General maintenance

(1) Radar cleaning: When the machine is shut down and not working, check the surroundings of the radar to ensure that there are no obstructions.

(2) Universal wheel cleaning: When the machine is shut down and not working, gently lift the chassis, wipe the universal wheel with a soft dry cloth, and remove the surrounding foreign matters.

(3) Depth camera lens cleaning: Please wipe the lenses of the depth cameras with a soft dry cloth when the machine is powered off.

(4) Cleaning the charging pile: Please wipe the charging pile and charging electrode with a soft dry cloth when the power is off.

(5) Collision bar cleaning: Please wipe the collision bar with a soft dry cloth when the power is off, and ensure that there are no wires, paper scraps and other foreign objects stuck on the anti-collision bar.

2. Maintenance cycle

For the maintenance of the main engine, it mainly includes depth camera lens inspection, collision bar inspection, clearance inspection around the radar, foreign matter inspection around the driving wheel and universal wheel, charging pile inspection, etc. The time interval of the maintenance cycle can be appropriately adjusted according to the environment, frequency, intensity and temperature of the machine.

Athena2.0 maintenance schedule			Time interval		
NO	Name	Maintenance level	Year	Month	Week
1	Depth camera lens	Clean	--	--	1 time
2	Collision bar	Clean	--	--	1 time
3	Around the radar	clearance	--	1 time	--
4	Universal wheel	Clean	--	--	1 time
5	Driving wheel	Clean	--	--	1 time
6	Charging pile	Clean	--	1 time	--
7	Machine body	Overhaul	1 time	--	--

10-1 Athena2.0 maintenance schedule

11. Common faults and troubleshooting

When an abnormality occurs during Athena2.0 operation, please refer to the following table or page tips to solve the problem:

NO	Fault prompt	Solutions
1	Collision bar abnormal	Please check whether the collision bar is jammed, and tap the anti-collision bar several times to return the anti-collision bar to its position.
2	Athena2.0 battery low	Please press the brake release button and push the machine back to the charging point to charge.
3	The charging point cannot be charged	Please check whether the power cord plug of the charging point is inserted into the socket and whether the indicator light of the charging point is on normally.
4	Unable to power on	Please check whether the charging point is connected to the power supply. After the charging point and Athena2.0 are connected normally, if it cannot be solved, please contact the after-sales service department.
5	Athena2.0 cannot be charged on the pile	Please try again on the charging pile. If you cannot solve it, please contact after-sales service.
6	Unable to go back to the charging point	1. Please confirm whether the position of the charging point has been moved. If the position has been moved, please contact the after-sales department. 2. Please confirm whether there is a slope at the position of the charging point. If there is a slope, please contact the after-sales department. 3. Please push Athena2.0 back to the charging point and try to restart Athena2.0.
7	Unable to get in / out of the elevator	1. Please confirm whether there are obstacles in the elevator. 2. Please confirm the internet signal near the elevator. 3. Please push Athena2.0 back to the charging point and try to restart Athena2.0.
8	Universal wheels rotate intermittently	Please check whether there are any foreign objects such as threads, cards, etc. around the universal wheels and the driving wheels. If there are foreign objects, please clean them.
9	Machine can't walk	Please check whether the drive cable is connected normally. If it cannot be solved, please contact the after-sales service.
10	The light strip does not light up	Please check whether the connecting wire of the light strip is connected normally. If it cannot be solved, please contact the after-sales service.

12. Certificate

Company name: Shanghai Slamtec Co., Ltd

Company Address: Unit 01, 2nd Floor, Building E, Shengyin Building, No.666 Shengxia Road, China (Shanghai) Pilot Free Trade Zone.

Contact information: (+86) 021 68581569